

工业 PVC-U/C 管材 / 管件 / 阀门

PVC-U/C PIPE / FITTING / VALVE

FOR INDUSTRY



CONTENTS

目录

ABOUT US 关于我们	01
------------------	----

CERTIFICATIONS 资质证书	03
------------------------	----

PRODUCT CATEGORY 产品类别	05
--------------------------	----

APPLICATION 行业应用	06
---------------------	----



PIPE 管材	07
------------	----

UPVC/CPVC 管材管件执行标准一览表 Table of Product Standards-UPVC/CPVC Pipes and Fittings	09
--	----

UPVC 管材管件执行标准一览表 Standards of UPVC Material Testing	09
--	----

CPVC 材料试验标准 Standards of CPVC Material Testing	10
---	----

工业 UPVC 管材系列和规格尺寸 SERIES AND SIZE OF UPVC PIPE FOR INDUSTRY	11
--	----

UPVC 美标管材 (ASTM)UPVC PIPES	12
-------------------------------	----

工业 CPVC 管材系列和规格尺寸 SERIES AND SIZE OF CPVC PIPE FOR INDUSTRY	13
--	----

CPVC 美标管材 (ASTM)CPVC PIPES	14
-------------------------------	----

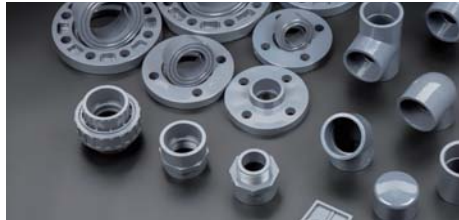

PIPE FITTING 管件	15
--------------------	----

90° 弯头, PVC-U/C (国标, 美标) PVC-U/C ELBOW 90°	17
---	----

45° 弯头, PVC-U/C (国标, 美标) PVC-U/C ELBOW 45°	19
---	----

正三通, PVC-U/C (国标, 美标) PVC-U/C TEE	21
--------------------------------------	----

异三通, PVC-U/C (国标, 美标) PVC-U/C REDUCING TEE	23
---	----

铜内丝 90° 弯头, PVC-U/C (国标) PVC-U/C COPPER THREADED ELBOW 90°	26
---	----

正四通, PVC-U/C (国标, 美标) PVC-U/C CROSS	27
--	----

变径 (补芯), PVC-U/C (国标, 美标) PVC-U/C BUSHING	29
--	----

铜内丝三通, PVC-U/C (国标) PVC-U/C COPPER THREADED TEE	32
--	----

异径, PVC-U/C (国标, 美标) PVC-U/C REDUCER	33
---	----

铜内丝直接, PVC-U/C (国标) PVC-U/C COPPER THREADED REDUCER	36
--	----

管堵, PVC-U/C (国标, 美标) PVC-U/C CAP	37
-------------------------------------	----

管箍, PVC-U/C (国标, 美标) PVC-U/C COUPLING	39
--	----

内丝, PVC-U/C (国标, 美标) PVC-U/C FEMALE ADAPTOR	41
--	----

外丝, PVC-U/C (国标, 美标) PVC-U/C MALE ADAPTOR	43
--	----

单片式法兰, PVC-U/C (国标, 美标) PVC-U/C ONE-PIECE FLANGE	45
---	----

活套平承法兰, PVC-U/C (国标, 美标) PVC-U/C VANSTONE FLANGE	47
---	----

盲法兰, PVC-U/C (国标, 美标) PVC-U/C BLIND FLANGE	49
---	----

由任 (由令), PVC-U/C (国标, 美标) PVC-U/C UNION	51
--	----

法兰垫, 三元乙丙橡胶, 氟橡胶 (EPDM, FPM) (国标, 美标) FLANGE GASKET	53
--	----

管卡, PVC-U (国标) PVC-U BRACKET	55
---------------------------------	----

丝口盲板 COPPER THREADED BLIND FLANGE	56
--------------------------------------	----



VALVE 阀门	57
-------------	----

插口双由令球阀, PVC-U/C (国标, 美标, 日标) PVC-U/C SOCKET TRUE UNION BALL VALVE	58
---	----

丝口式双由令球阀, PVC-U/C (国标, 美标, 日标) PVC-U/C THREADED TRUE UNION BALL VALVE	61
--	----

法兰式双由令球阀, PVC-U/C (国标) PVC-U/C FLANGED TRUE UNION BALL VALVE	64
---	----

气动插口式双由令球阀, PVC-U/C (国标, 美标, 日标) PVC-U/C PNEUMATIC SOCKET TRUE UNION BALL VALVE	66
--	----

气动法兰式双由令球阀, PVC-U/C (国标) PVC-U/C PNEUMATIC FLANGED TRUE UNION BALL VALVE	69
---	----

气动丝口式双由令球阀, PVC-U/C (国标, 美标, 日标) PVC-U/C PNEUMATIC THREADED TRUE UNION BALL VALVE	71
--	----

电动插口式双由令球阀, PVC-U/C (国标, 美标, 日标) PVC-U/C ELECTRIC SOCKET TRUE UNION BALL VALVE	74
---	----

电动法兰式双由令球阀, PVC-U/C (国标) PVC-U/C ELECTRIC FLANGED TRUE UNION BALL VALVE	77
--	----

电动丝口式双由令球阀, PVC-U/C (国标, 美标, 日标) PVC-U/C ELECTRIC THREADED TRUE UNION BALL VALVE	79
---	----

手动式蝶阀, PVC-U/C (国标, 美标, 日标) PVC-U/C HANDLE BUTTERFLY VALVE	82
---	----

齿轮式蝶阀 (国标, 美标, 日标) PVC-U/C GEARED BUTTERFLY VALVE	85
--	----

气动式蝶阀, PVC-U/C (国标, 美标, 日标) PVC-U/C PNEUMATIC BUTTERFLY VALVE	88
--	----

电动式蝶阀, PVC-U/C (国标, 美标, 日标) PVC-U/C ELECTRIC BUTTERFLY VALVE	91
---	----

法兰式隔膜阀, PVC-U/C (国标) PVC-U/C FLANGED DIAPHRAGM VALVE	94
---	----

插口式隔膜阀, PVC-U/C (国标, 美标) PVC-U/C SOCKET DIAPHRAGM VALVE	97
--	----

由令式插口隔膜阀, PVC-U/C (国标, 美标, 日标) PVC-U/C TRUE UNION DIAPHRAGM VALVE	100
--	-----

插口式双由令止回阀, PVC-U/C (国标, 美标, 日标) PVC-U/C SOCKET TRUE UNION CHECK VALVE	103
--	-----

丝口式双由令止回阀, PVC-U/C (国标, 美标, 日标) PVC-U/C THREADED TRUE UNION CHECK VALVE	106
--	-----

法兰式双由令止回阀, PVC-U/C (国标) PVC-U/C FLANGED TRUE UNION CHECK VALVE	109
---	-----

旋启式止回阀, PVC-U/C (国标, 美标, 日标) PVC-U/C SWING SPRING CHECK VALVE	112
--	-----

ABOUT US

关于我们

工业 PVC-U/C 管材 / 管件 / 阀门

PVC-U/C PIPE/FITTING/VALVE
FOR INDUSTRY

EXPERT IN PIPING SYSTEM

管路系统的专家级工厂

重信求实 华生企业的灵魂
开拓创新 永恒发展的动力

以质取胜、以质取信，为顾客提供满意的产品和服务



▶ 公司简介

华生管道科技有限公司始建于1988年，坐落于江苏常州高新技术产业开发区，是一家集UPVC、CPVC、PE、PPH、PVDF、AGR等材质的工业、给水、环保水处理设备类塑料管道产品研发、制造于一体的管路系统专业生产企业。经过多年的探索与提升，目前华生已成为行业内的领先企业，是江苏省塑料管道系统工程技术中心依托单位，中国塑料加工工业协会塑料管道专业委员会会员单位，中国电子材料行业协会会员单位。中国氯碱工业协会会员单位，中国电子电路行业协会会员单位。

▶ 公司实力

公司占地面积20万平方米，拥有固定资产6亿元人民币。公司现有员工400多人，下设模具事业部、管路系统事业部、精密注塑事业部。原料混配系统6套，造粒生产线8条，管材挤出生产线30条，注塑机200多台，大型加工中心等机械加工设备80多台，年生产能力达80000吨。

▶ 资质 & 荣誉

目前公司已经通过ISO9001、ISO14001、OHSAS18001等体系的认证，以及美国卫生基金国际组织NSF认证。公司被认定为江苏省高新技术企业，“华生”商标荣获江苏省著名商标。拥有江苏省高新技术产品3项，授权专利47项，获得江苏省市场监督管理局颁发的《中华人民共和国特种设备制造许可证（压力管道元件）》和江苏省卫计委颁发的《涉水产品卫生行政许可批件》，并入选《全国水利系统优秀产品招标重点推荐目录》。

CERTIFICATIONS

资质证书

客户至上, 优质高效, 绿色环保, 顾客满意。



PRODUCT CATEGORY

产品类别

▶ 给水、工业、环保水处理系列管材

20mm~800mm
S4/S5/S6.3/S8/S10/S12.5/S16/S20
1/2"-24"
SCH40/SCH80



管材 / PIPE

▶ 给水、工业、环保水处理系列管件

(PN10、PN12.5、PN16)
柔性管件 (带胶圈管件) 63mm~355mm
胶粘式管件 (PN10、PN12.5、PN16) 20mm~500mm
SCH80 1/2"-16"



管件 / PIPE FITTING

▶ 阀门类

球阀 (插口、丝口)
20mm~110mm; 1/2"-4"
双由令球阀 (手柄式、气动式、电动式)
20mm~110mm; 1/2"-4" 16A~100A
蝶阀 (手柄式、齿轮式、气动式、电动式)
63mm~400mm; 2"-16" 50A~318A
隔膜阀 (法兰式、插口式、由令式)
20mm~160mm; 1/2"-6" 16A~50A
止回阀 (单由令式、双由令式、摆动式、旋启式)
20mm~160mm; 1/2"-6" 16A~100A
底阀 (由令式、摆动式)
20mm~160mm



阀门 / VALVE

APPLICATION

行业应用



管路系统的专家级工厂 EXPERT IN PIPING SYSTEM



• 化工行业 • 建筑行业 • 水处理行业 • 医疗制药行业
• 电子行业 • 冶金行业 • 食品加工行业 • 农业灌溉行业



管材 PIPE

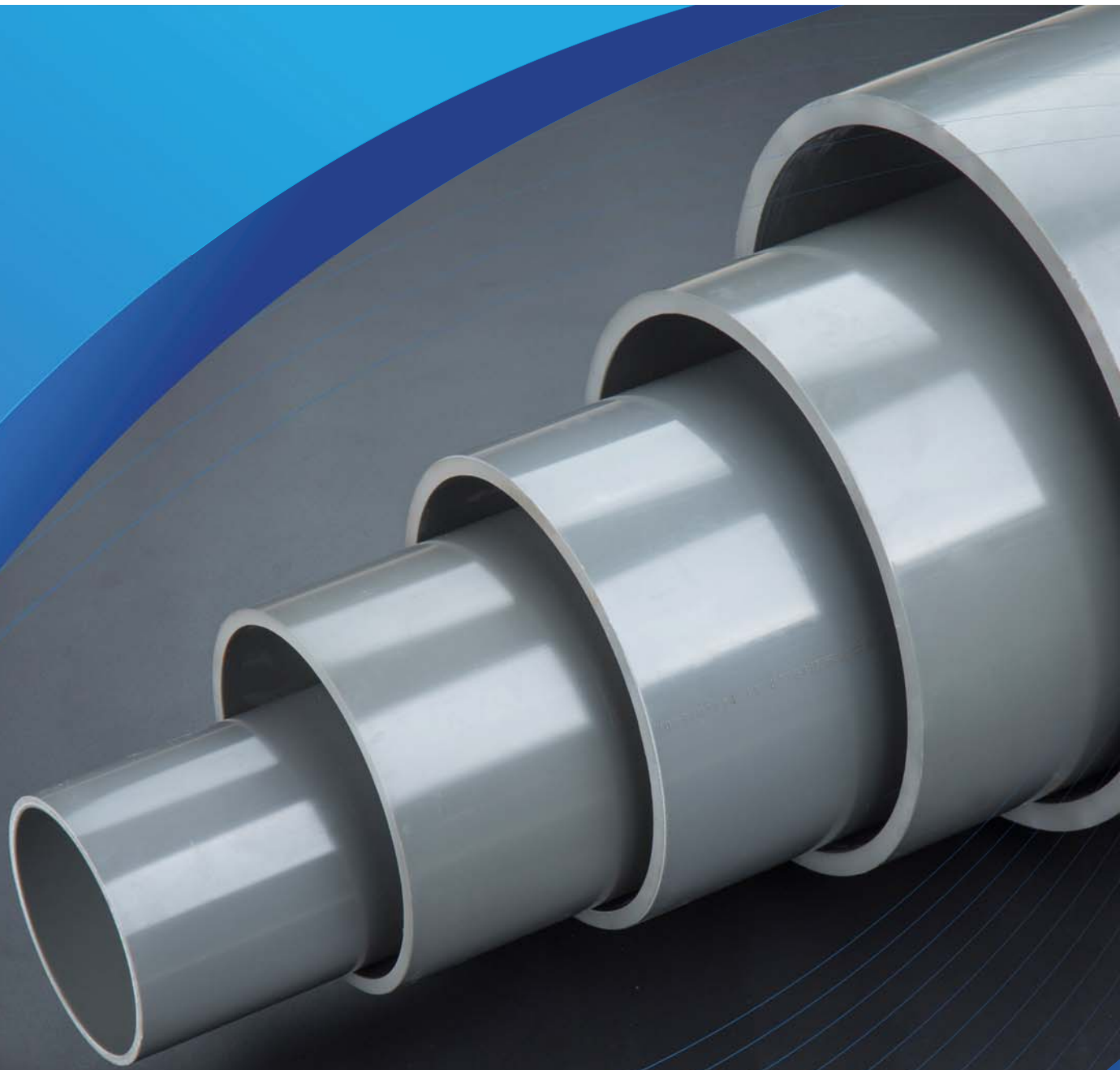

SERIES AND SIZE OF UPVC PIPE FOR INDUSTRY

工业 UPVC 管材系列和规格尺寸

管材介绍

管材特点

1. 物化性能优良。用 UPVC 生产的管材及管件，耐腐蚀，抗冲强度高，流体阻力小（较同口径铸铁管流量提高 30%）。耐老化，使用寿命长（据权威机构测试资料说明，使用年限为 40-50 年），是建筑排水、化工排污的理想材料。
2. 质地实用，安装方便。重量只有同口径铸铁管 1/7，可大大加快工程进度和降低施工费用。
3. 内壁光滑，排水流畅，管道不易堵塞。
4. 节约建筑费用。使用 UPVC 管比使用同样规格的铸铁管的综合造价低，维修费用低。

产品参数

GB/T 4219.1-2008 单位: 毫米 unit:mm

公称外径 dn Nominal Outside Diameter Dn	外形尺寸 Dimensions (mm)													
	S20 / SDR41		S16 / SDR33		S12.5 / SDR26		S10 / SDR21		S8 / SDR17		S6.3 / SDR13.6		S5 / SDR11	
	E _{min}	公差 Tolerance	E _{min}	公差 Tolerance	E _{min}	公差 Tolerance	E _{min}	公差 Tolerance	E _{min}	公差 Tolerance	E _{min}	公差 Tolerance	E _{min}	公差 Tolerance
16	-	-	-	-	-	-	-	-	-	-	-	-	2.0	+0.4
20	-	-	-	-	-	-	-	-	-	-	-	-	2.0	+0.4
25	-	-	-	-	-	-	-	-	-	-	2.0	+0.4	2.3	+0.5
32	-	-	-	-	-	-	-	2.0	+0.4	2.4	+0.5	2.9	+0.5	
40	-	-	-	-	-	-	2.0	+0.4	2.4	+0.5	3.0	+0.5	3.7	+0.6
50	-	-	-	-	2.0	+0.4	2.4	+0.5	3.0	+0.5	3.7	+0.6	4.6	+0.7
63	-	-	2.0	+0.4	2.5	+0.5	3.0	+0.5	3.8	+0.6	4.7	+0.7	5.8	+0.8
75	-	-	2.3	+0.5	2.9	+0.5	3.6	+0.6	4.5	+0.7	5.6	+0.8	6.8	+0.9
90	-	-	2.8	+0.5	3.5	+0.6	4.3	+0.7	5.4	+0.8	6.7	+0.9	8.2	+1.1
110	-	-	3.4	+0.6	4.2	+0.7	5.3	+0.8	6.6	+0.9	8.1	+1.1	10.0	+1.2
125	-	-	3.9	+0.6	4.8	+0.7	6.0	+0.8	7.4	+1.0	9.2	+1.2	11.4	+1.4
140	-	-	4.3	+0.7	5.4	+0.8	6.7	+0.9	8.3	+1.1	10.3	+1.3	12.7	+1.5
160	4.0	+0.6	4.9	+0.7	6.2	+0.9	7.7	+1.0	9.5	+1.2	11.8	+1.4	14.6	+1.7
180	4.4	+0.7	5.5	+0.8	6.9	+0.9	8.6	+1.1	10.7	+1.3	13.3	+1.6	16.4	+1.9
200	4.9	+0.7	6.2	+0.9	7.7	+1.0	9.6	+1.2	11.9	+1.4	14.7	+1.7	18.2	+2.1
225	5.5	+0.8	6.9	+0.9	8.6	+1.1	10.8	+1.3	13.4	+1.6	16.6	+1.9	-	-
250	6.2	+0.9	7.7	+1.0	9.6	+1.2	11.9	+1.4	14.8	+1.7	18.4	+2.1	-	-
280	6.9	+0.9	8.6	+1.1	10.7	+1.3	13.4	+1.6	16.6	+1.9	20.6	+2.3	-	-
315	7.7	+1.0	9.7	+1.2	12.1	+1.5	15.0	+1.7	18.7	+2.1	23.2	+2.6	-	-
355	8.7	+1.1	10.9	+1.3	13.6	+1.6	16.9	+1.9	21.1	+2.4	26.1	+2.9	-	-
400	9.8	+1.2	12.3	+1.5	15.3	+1.8	19.1	+2.2	23.7	+2.6	29.4	+3.2	-	-
450	11.0	+1.3	13.8	+1.6	17.2	+2.0	21.5	+2.4	26.7	+3.0	33.1	+3.6	-	-
500	12.3	+1.5	15.3	+1.8	19.1	+2.2	23.9	+2.6	29.7	+3.2	36.8	+3.9	-	-
560	13.7	+1.6	17.2	+2.0	21.4	+2.4	26.7	+2.9	-	-	-	-	-	-
630	15.4	+1.8	19.3	+2.2	24.1	+2.7	30.0	+3.2	-	-	-	-	-	-
710	17.4	+2.0	21.8	+2.4	27.2	+3.0	-	-	-	-	-	-	-	-
800	19.6	+2.2	24.5	+2.7	30.6	+3.3	-	-	-	-	-	-	-	-

注 1: 考虑到安全性, 最小壁厚应不小于 2.0mm. The minimum wall thickness is no less than 2.0mm for security.

注 2: 除了有其他规定之外, 尺寸应与 GB/T10798 一致. The size should conform to GB/T10798 unless otherwise specified.

(ASTM)UPVC PIPE UPVC 美标管材

SCH40

产品参数

ASTM D1785 单位: 毫米 unit:mm

尺寸 Size(英寸)	壁厚 Wall thickness(mm)	外径 Outer diameter	公差 Tolerance of wall thickness
1/2"	2.77	21.34	0~+0.51
3/4"	2.87	26.67	0~+0.51
1"	3.38	33.4	0~+0.51
1-1/4"	3.56	42.16	0~+0.51
1-1/2"	3.68	48.26	0~+0.51
2"	3.91	60.32	0~+0.51
2-1/2"	5.16	73.02	0~+0.61
3"	5.49	88.9	0~+0.66
4"	6.02	114.3	0~+0.71
5"	6.55	141.3	0~+0.79
6"	7.11	168.28	0~+0.79
8"	8.18	219.08	0~+0.86
10"	9.27	273.05	0~+1.12
12"	10.31	323.85	0~+1.24
14"	11.10	355.6	0~+1.35
16"	12.70	406.4	0~+1.52
18"	14.27	457.2	0~+1.7
20"	15.06	508	0~+1.8
24"	17.45	609.6	0~+2.08

SCH80

产品参数

ASTM D1785 单位: 毫米 unit:mm

尺寸 Size(英寸)	壁厚 Wall thickness(mm)	外径 Outer diameter	公差 Tolerance of wall thickness
1/2"	3.73	21.34	0~+0.51
3/4"	3.91	26.67	0~+0.51
1"	4.55	33.4	0~+0.53
1-1/4"	4.85	42.16	0~+0.58
1-1/2"	5.08	48.26	0~+0.61
2"	5.54	60.32	0~+0.66
2-1/2"	7.01	73.02	0~+0.84
3"	7.62	88.9	0~+0.91
4"	8.56	114.3	0~+1.02
5"	9.52	141.3	0~+1.14
6"	10.97	168.28	0~+1.32
8"	12.70	219.08	0~+1.52
10"	15.06	273.05	0~+1.80
12"	17.45	323.85	0~+2.08
14"	19.05	355.6	0~+2.29
16"	21.41	406.4	0~+2.57
18"	23.8	457.2	0~+2.84
20"	26.19	508	0~+3.15
24"	30.94	609.6	0~+3.71

SERIES AND SIZE OF CPVC PIPE FOR INDUSTRY

工业 CPVC 管材系列和规格尺寸

管材介绍

管材特点

- 1.CPVC 由聚氯乙烯 (PVC) 树脂氯化改性制得, 是一种新型工程塑料。该产品为灰色或淡黄色无味、无臭、无毒的疏松颗粒或粉末。PVC 树脂经过氯化以后, 分子键的不规则性增加; 极性增加; 使溶解性增大; 化学稳定性增加; 耐热性提高。
- 2.CPVC 管道是以氯化聚氯乙烯树脂为主要原料, 加入为提高其加工性能所必须的添加剂, 挤出 (管材) 或注塑 (管件) 成型的产品。

产品参数

GB/T 18998.2-2003 单位: 毫米 unit:mm

公称外径 dn Nominal Outside Diameter Dn	外形尺寸 Dimensions (mm)							
	S10 / SDR21		S6.3 / SDR13.6		S5 / SDR11		S4 / SDR9	
	e _{min}	公差 Tolerance	e _{min}	公差 Tolerance	e _{min}	公差 Tolerance	e _{min}	公差 Tolerance
20	2.0(0.96)*	0+0.4	2.0(1.5)*	0+0.4	2.0(1.9)*	0+0.4	2.3	0+0.5
25	2.0(1.2)*	0+0.4	2.0(1.9)*	0+0.4	2.3	0+0.5	2.8	0+0.5
32	2.0(1.6)*	0+0.4	2.4	0+0.5	2.9	0+0.5	3.6	0+0.6
40	2.0(1.9)*	0+0.4	3.0	0+0.5	3.7	0+0.6	4.5	0+0.7
50	2.4	0+0.5	3.7	0+0.6	4.6	0+0.7	5.6	0+0.8
63	3.0	0+0.5	4.7	0+0.7	5.8	0+0.8	7.1	0+1.0
75	3.6	0+0.6	5.6	0+0.8	6.8	0+0.9	8.4	0+1.1
90	4.3	0+0.7	6.7	0+0.9	8.2	0+1.1	10.1	0+1.3
110	5.3	0+0.8	8.1	0+1.1	10.0	0+1.2	12.3	0+1.5
125	6.0	0+0.8	9.2	0+1.2	11.4	0+1.4	14.0	0+1.6
140	6.7	0+0.9	10.3	0+1.3	12.7	0+1.5	15.7	0+1.8
160	7.7	0+1.0	11.8	0+1.4	14.6	0+1.7	17.9	0+2.0
180	8.6	0+1.1	13.3	0+1.6	-	-	-	-
200	9.6	0+1.2	14.7	0+1.7	-	-	-	-
225	10.8	0+1.3	16.6	0+1.9	-	-	-	-
250	11.9	0+1.4	18.4	0+2.1	-	-	-	-
280	13.4	0+1.6	20.6	0+2.3	-	-	-	-
315	15.0	0+1.7	23.2	0+2.6	-	-	-	-
355	16.9	0+1.9	26.1	0+2.9	-	-	-	-
400	19.1	0+2.2	29.4	0+3.2	-	-	-	-

注: 考虑到刚度要求, 带 "*" 号规格的管材壁厚增加到 2.0mm, 计算液压试验压力时使用括号中的壁厚。
 Note: Consider the request of stiffness, the minimum wall thickness marked with "*" size added to 2.0mm.
 Use the wall thickness in parenthesis when calculating the hydrostatic test press.

(ASTM)CPVC PIPE CPVC 美标管材

SCH40

产品参数

ASTM F441 单位: 毫米 unit:mm

尺寸 Size (")	尺寸 Wall thickness (mm)	外径 Outer diameter	尺寸 Tolerance of wall thickness
1/2"	2.77	21.34	0+0.51
3/4"	2.87	26.67	0+0.51
1"	3.38	33.4	0+0.51
1-1/4"	3.56	42.16	0+0.51
1-1/2"	3.68	48.26	0+0.51
2"	3.91	60.32	0+0.51
2-1/2"	5.16	73.02	0+0.61
3"	5.49	88.9	0+0.66
4"	6.02	114.3	0+0.71
5"	6.55	141.3	0+0.79
6"	7.11	168.28	0+0.79
8"	8.18	219.08	0+0.86
10"	9.27	273.05	0+1.12
12"	10.31	323.85	0+1.24
14"	11.10	355.6	0+1.35
16"	12.70	406.4	0+1.52

SCH80

产品参数

ASTM F441 单位: 毫米 unit:mm

尺寸 Size (")	尺寸 Wall thickness (mm)	外径 Outer diameter	尺寸 Tolerance of wall thickness
1/2"	3.73	21.34	0+0.51
3/4"	3.91	26.67	0+0.51
1"	4.55	33.4	0+0.53
1-1/4"	4.85	42.16	0+0.58
1-1/2"	5.08	48.26	0+0.61
2"	5.54	60.32	0+0.66
2-1/2"	7.01	73.02	0+0.84
3"	7.62	88.9	0+0.91
4"	8.56	114.3	0+1.02
5"	9.52	141.3	0+1.14
6"	10.97	168.28	0+1.32
8"	12.70	219.08	0+1.52
10"	15.06	273.05	0+1.80
12"	17.45	323.85	0+2.08
14"	19.05	355.6	0+2.29
16"	21.41	406.4	0+2.57

Table of Product Standards-UPVC/CPVC Pipes and Fittings

UPVC/CPVC 管材管件执行标准一览表

种类 Type	执行标准 Product Standards
UPVC 给水管件 (国标) (DIN)UPVC Fittings For Water Supply	GB/T 10002.2-2003 BS EN ISO 1452
UPVC 化工管件 (国标) (DIN)UPVC Fittings For Industry	GB/T 4219.2-2015
UPVC 牙口式美标管件 (ASTM)Threaded Type UPVC Fittings	ASTM D2464
UPVC 承插式美标管件 (ASTM)Socket Type UPVC Fittings	ASTM D2467
CPVC 化工管件 (国标) (DIN)CPVC Fittings For Industry	GB/T 18998.3-2003
CPVC 牙口式美标管件 (ASTM)Threaded Type CPVC Fittings	ASTM F437
CPVC 承插式美标管件 (ASTM)Socket Type CPVC Fittings	ASTM F439
UPVC 给水管材 (国标) (DIN) UPVC Pipes For Water Supply	GB/T 10002.1-2006
UPVC 化工管材 (国标) (DIN) UPVC Pipes For Industry	GB/T 4219.1-2008
UPVC 美标 管材 (ASTM) UPVC Pipes	ASTM D 1785
CPVC 给水管材 (国标) (DIN) CPVC Pipes For Water Supply	GB/T 18993.2-2003
CPVC 化工管材 (国标) (DIN) CPVC Pipes For Industry	GB/T 18998.2-2003
CPVC 美标管材 (ASTM) CPVC Pipes	ASTM F441

Standards of UPVC Material Testing

UPVC 材料试验标准

指标名称 Index Name	单位 Unit	指标 Index	试验方法 Test method
密度 Density	kg/m ³	1350-1460	按 GB/T 1033-1986 规定 A 法测定 Method A of GB 1033
维卡软化温度 Vicat Softening Temperature	°C	管材 ≥80 管件 ≥74	GB/T 8802-2001
静液压测试 Hydraulic Test		不破裂, 不渗水 No Breakage, no leakage	GB/T 6111-2003
纵向回缩率 Longitudinal Reversion	%	≤5	GB/T 6671-2001
二氯甲烷浸泡 Dichloromethane Soak		试样表面无损坏 No damage on surface of sampe	GB/T 13526-2007

Standards of CPVC Testing Material

CPVC 材料试验标准

指标名称 Index Name	单位 Unit	指标 Index	试验方法 Test method
密度 Density	kg/m ³	1450-1650	GB/T 1033-1986 方法 A Method A of GB/T 1033-1986
维卡软化温度 (管材) Vicat Softening Temperature(Pipes)	°C	≥110	GB/T 8802-2001
维卡软化温度 (管件) Vicat Softening Temperature(Fittings)	°C	≥103	GB/T 8802-2001
纵向回缩率 Longitudinal Reversion	%	≤5	GB/T6671-2001 方法 B Method B of GB/T6671-2001
氯含量 (质量百分比) Chlorine Concentration (Mass Percent)	%	≥60	GB/T 7139-2002
静液压试验 Hydrostatic Test	--	无脱层, 无破碎 No leafing,no break	ISO 1167:1996
静液压状态下热稳定试验 Hydrostatic Reheat Test	--	无脱层, 无破碎 No leafing,no break	ISO 1167
落锤冲击试验 Drop Impact Test	Cal/g/°C	TIR≤10%	GB/T 14152
烘箱试验 Oven Test	MPa	无分层, 无开裂 No lamination,no crack	GB/T 8803
弹性模量 * Modulus of Elasticity	MPa	≥2660	ASTM D638
拉伸强度 * Tensile Strength	KJ/m ²	≥56	ASTM D638
冲击强度 * Impact Strength	m/m°C	≥16	ASTM D256
线膨胀系数 * Coefficient of Linear Expansion	Cal/g/°C	3.4x10 ⁻⁵	--
热传导率 * Thermal Conductivity	Cal/g/°C	0.14	ASTM C177
比热 * Specific Heat	Ω/cm	0.14	--
体电阻 * Bulk Resistance	AC,KV/mm	≥1015	--
介电强度 * Dielectric Strength	--	13	--
阻燃性 * Flame Retardant	--	自熄 Self-extinguish	UL-94

管件 PIPE FITTING



PVC-U/C ELBOW 90°

90°弯头, PVC-U/C (国标、美标)

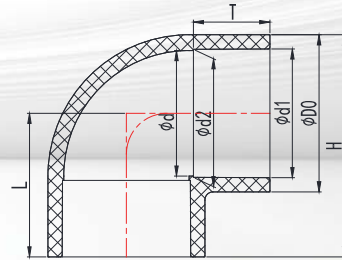

产品参数 (国标 DIN)

尺寸 Size DN	外形尺寸 Dimensions (mm)							公称压力 Nominal Pressure PN(kg/cm ²)
	D0	d1	d2	d	T	L	H	
15	26.30	20.30	19.95	18.00	16.20	27.70	40.80	S5(PN20)
20	31.80	25.30	24.95	23.00	18.70	32.70	48.60	S5(PN20)
25	39.90	32.30	31.90	30.00	22.20	39.70	59.60	S5(PN20)
32	49.70	40.40	39.90	38.00	26.20	47.70	72.50	S5(PN20)
40	61.90	50.40	49.90	48.00	31.20	57.70	88.70	S5(PN20)
50	77.90	63.40	62.90	61.00	37.70	70.70	109.70	S5(PN20)
65	91.00	75.40	74.90	70.90	43.70	82.50	128.00	S6.3(PN16)
80	107.40	90.50	89.90	85.90	51.20	97.50	151.20	S6.3(PN16)
100	127.00	110.60	109.90	103.90	61.20	117.50	181.10	S6.3(PN16)
De125	144.30	125.70	124.90	118.90	68.70	132.50	204.70	S6.3(PN16)
125	162.30	140.80	139.90	133.90	76.20	148.00	229.10	S6.3(PN16)
150	184.60	160.80	159.90	153.50	86.20	168.50	260.80	S6.3(PN16)
De180	202.60	180.90	179.90	178.50	97.00	190.00	291.30	S6.3(PN16)
De200	230.50	201.00	199.90	193.50	106.20	208.00	323.30	S6.3(PN16)
200	259.40	226.20	224.90	216.90	119.10	233.60	363.20	S6.3(PN16)
De250	287.90	251.30	249.90	241.90	131.65	258.50	402.50	S8(PN16)
250	314.80	281.50	279.90	278.00	147.00	291.00	448.40	S8(PN16)
300	358.20	316.70	314.90	306.90	164.30	323.00	502.10	S8(PN16)
350	391.00	356.80	355.00	326.00	184.30	368.30	561.40	PN6
400	442.00	402.00	400.00	369.80	204.20	413.00	629.40	PN6

产品参数 (美标 ASTM SCH80)

尺寸 Size (*")	外形尺寸 Dimensions (mm)						
	D0	d1	d2	d	T	L	H
1/2"	30.50	21.54	21.23	17.00	23.22	36.25	51.50
3/4"	36.90	26.87	26.57	22.50	26.40	41.40	59.85
1"	44.70	33.66	33.27	29.00	29.57	47.10	69.45
1-1/4"	54.00	42.42	42.04	38.00	32.75	55.75	82.75
1-1/2"	60.60	48.56	48.11	43.00	35.93	61.95	92.25
2"	73.10	60.63	60.17	55.00	39.10	70.85	107.40
2-1/2"	88.40	73.38	72.85	67.50	45.45	84.50	128.70
3"	105.30	89.31	88.70	83.00	48.63	97.63	149.30
4"	132.00	114.76	114.07	106.00	58.15	117.25	183.25
5"	161.90	141.81	141.04	133.00	67.68	143.50	224.45
6"	190.90	168.83	168.00	160.00	77.20	166.25	261.70
8"	245.90	219.84	218.69	208.00	102.60	216.30	340.55
10"	305.80	273.81	272.67	262.50	128.00	278.00	430.90
12"	361.60	324.60	323.47	288.50	153.40	328.50	509.70
14"	394.11	355.94	354.33	331.50	200.00	375.75	576.00
16"	450.00	407.19	405.33	363.80	230.66	431.50	657.50

PVC-U/C ELBOW 45°

45°弯头, PVC-U/C (国标, 美标)

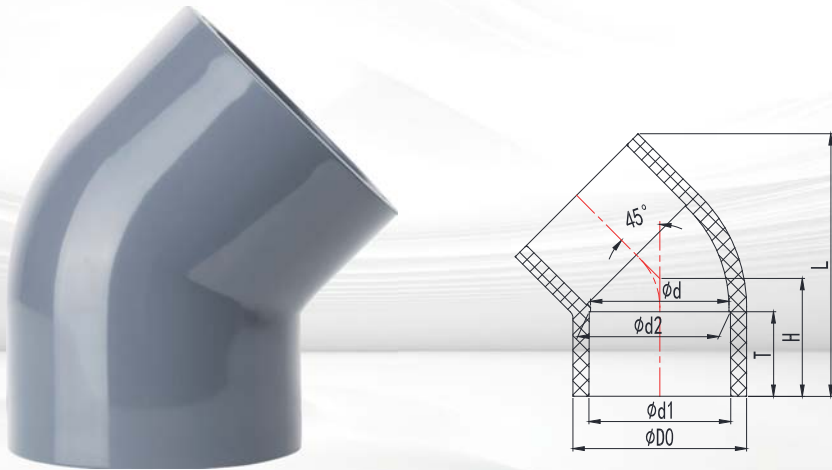

产品参数 (国标 DIN)

尺寸 Size DN	外形尺寸 Dimensions (mm)							公称压力 Nominal Pressure PN(kg/cm²)
	D0	d1	d2	d	T	H	L	
15	26.30	20.30	19.95	18.00	16.20	22.10	46.90	S5(PN20)
20	31.80	25.30	24.95	23.00	18.70	25.70	54.90	S5(PN20)
25	38.60	32.30	31.90	30.00	22.20	30.60	66.20	S5(PN20)
32	49.70	40.40	39.90	38.00	26.20	36.30	79.30	S5(PN20)
40	61.90	50.40	49.90	48.00	31.20	43.30	95.70	S5(PN20)
50	77.50	63.40	62.90	61.00	37.70	52.50	116.90	S5(PN20)
65	91.20	75.40	74.90	70.90	43.70	64.60	142.50	S6.3(PN16)
80	107.60	90.50	89.90	85.90	51.20	75.60	166.90	S6.3(PN16)
100	127.00	110.60	109.90	103.90	61.20	89.20	197.60	S6.3(PN16)
De125	144.30	125.70	124.90	118.90	68.70	100.70	222.90	S6.3(PN16)
125	161.60	140.80	139.90	133.90	76.20	112.40	248.90	S6.3(PN16)
150	184.60	160.80	159.90	153.90	86.20	126.90	281.90	S6.3(PN16)
De180	202.60	180.90	179.90	178.50	97.00	137.90	307.00	S6.3(PN16)
De200	230.50	201.00	199.90	193.50	106.20	157.10	349.50	S6.3(PN16)
200	259.40	226.20	224.90	216.90	119.10	175.70	391.50	S6.3(PN16)
De250	287.90	251.30	249.90	241.90	131.65	193.30	432.20	S8(PN16)
250	314.80	281.50	279.90	278.00	147.00	209.60	469.10	S8(PN16)
300	358.20	316.70	314.90	306.90	164.30	242.80	541.20	S8(PN16)
350	391.00	356.80	355.00	326.00	184.30	272.80	602.20	PN6
400	442.00	402.00	400.00	369.80	204.20	298.50	662.20	PN6

产品参数 (美标 ASTM SCH80)

尺寸 Size (*")	外形尺寸 Dimensions (mm)						
	D0	d1	d2	d	T	H	
1/2"	30.50	21.54	21.23	17.00	23.22	29.72	
3/4"	35.27	26.87	26.57	22.50	26.40	34.40	
1"	43.66	33.66	33.27	29.00	29.57	37.58	
1-1/4"	53.02	42.42	42.04	38.00	32.75	42.75	
1-1/2"	59.86	48.56	48.11	43.00	35.93	47.93	
2"	72.22	60.63	60.17	55.00	39.10	55.10	
2-1/2"	88.00	73.38	72.85	67.50	45.45	63.50	
3"	105.30	89.31	88.70	83.00	48.63	68.63	
4"	132.00	114.76	114.07	106.00	58.15	84.15	
5"	161.90	141.81	141.04	133.00	67.68	104.55	
6"	190.90	168.83	168.00	160.00	77.20	122.20	
8"	245.90	219.84	218.69	208.00	102.60	153.80	
10"	305.20	273.80	272.67	262.50	128.00	188.00	
12"	358.15	324.60	323.47	311.00	164.30	242.80	
14"	394.11	355.94	354.33	331.50	200.00	270.94	
16"	450.00	407.19	405.33	363.80	230.66	306.81	

PVC-U/C TEE

正三通, PVC-U/C (国标, 美标)

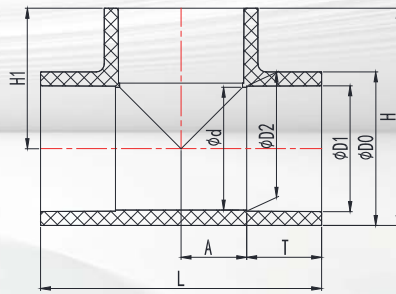

产品参数 (国标 DIN)

尺寸 Size DN	外形尺寸 Dimensions (mm)								公称压力 Nominal Pressure PN(kg/cm ²)
	D0	D1	D2	d	T	L	H1	H	
15	26.30	20.30	19.95	18.00	16.20	55.40	27.70	40.85	S5(PN20)
20	31.80	25.30	24.95	23.00	18.70	65.40	32.70	48.60	S5(PN20)
25	39.90	32.30	31.90	30.00	22.20	79.40	39.70	59.65	S5(PN20)
32	49.70	40.40	39.90	38.00	26.20	97.20	47.70	72.55	S5(PN20)
40	61.90	50.40	49.90	48.00	31.20	114.50	57.70	88.65	S5(PN20)
50	77.90	63.40	62.90	61.00	37.70	141.00	70.70	109.65	S5(PN20)
65	91.20	75.40	74.90	70.90	43.70	165.00	82.50	128.10	S6.3(PN16)
80	107.60	90.50	89.90	85.90	51.20	194.00	97.50	151.30	S6.3(PN16)
100	127.00	110.60	109.90	103.90	61.20	234.00	117.50	181.00	S6.3(PN16)
De125	144.30	125.70	124.90	118.90	68.70	264.00	132.50	204.65	S6.3(PN16)
125	161.60	140.80	139.90	133.90	76.20	296.00	148.00	228.80	S6.3(PN16)
150	184.60	160.80	159.90	153.90	86.20	334.00	168.00	260.30	S6.3(PN16)
De180	202.60	180.90	179.90	178.50	97.00	380.00	190.00	291.30	S6.3(PN16)
De200	230.50	201.00	199.90	193.50	106.20	415.00	208.00	323.25	S6.3(PN16)
200	259.40	226.20	224.90	216.90	119.10	463.50	233.50	363.20	S6.3(PN16)
De250	287.90	251.30	249.90	241.90	131.65	516.00	258.50	402.45	S8(PN16)
250	314.80	281.50	279.90	278.00	147.00	581.50	291.00	448.40	S8(PN16)
300	358.20	316.70	314.90	306.90	164.30	645.00	323.00	502.10	S8(PN16)
350	391.00	356.80	355.00	326.00	184.30	736.00	368.50	564.00	PN6
400	442.00	402.00	400.00	369.80	204.20	825.00	413.00	634.00	PN6

产品参数 (美标 ASTM SCH80)

尺寸 Size (*")	外形尺寸 Dimensions (mm)							
	D0	D1	D2	d	T	H1	H	L
1/2"	30.14	21.54	21.23	17.00	23.22	36.25	51.50	72.50
3/4"	35.87	26.87	26.57	22.50	26.40	41.40	59.85	82.80
1"	44.30	33.66	33.27	29.00	29.57	47.10	69.45	94.20
1-1/4"	53.42	42.42	42.04	38.00	32.75	55.75	82.75	111.50
1-1/2"	60.40	48.56	48.11	43.00	35.93	62.00	92.25	124.00
2"	73.10	60.63	60.17	55.00	39.10	70.85	107.40	141.70
2-1/2"	88.40	73.38	72.85	67.50	45.45	83.28	128.70	166.55
3"	105.70	89.31	88.70	83.00	48.63	97.08	149.30	194.15
4"	132.50	114.76	114.07	106.00	58.15	117.25	183.25	234.50
5"	161.60	141.81	141.04	133.00	67.68	142.80	227.95	285.60
6"	192.00	168.83	168.00	160.00	77.20	166.25	261.70	332.50
8"	246.50	219.84	218.69	208.00	102.60	217.60	340.55	435.20
10"	305.80	273.81	272.67	262.50	128.00	278.00	430.90	556.00
12"	361.60	324.60	323.47	313.00	153.40	328.50	509.70	656.80
14"	394.11	355.94	354.33	331.50	200.00	371.10	571.60	742.20
16"(FRP)	450.00	407.19	405.33	363.80	230.66	414.00	640.50	828.00

PVC-U/C REDUCING TEE

异三通, PVC-U/C (国标, 美标)

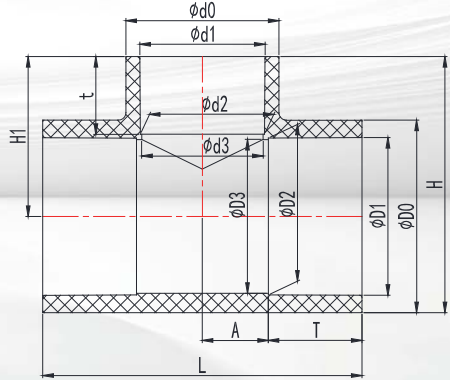

产品参数 (国标 DIN)

尺寸 Size DN(De)	外形尺寸 Dimensions (mm)												公称压力 Nominal Pressure PN(kg/cm ²)	
	D0	D1	D2	D3	d0	d1	d2	d3	T	t	H1	H		L
20X15(25*20)	31.80	25.25	24.95	23.00	26.30	20.30	19.95	18.00	18.70	16.20	30.20	46.1	60.40	S5(PN20)
25X15(32*20)	39.90	32.30	31.90	30.00	26.50	20.30	19.95	18.00	22.20	16.20	34.40	54.35	69.00	S5(PN20)
25X20(32*25)	39.90	32.30	31.90	30.00	31.80	25.30	24.95	23.00	22.20	16.20	36.20	56.15	72.10	S5(PN20)
32X15(40*20)	49.70	40.35	39.90	38.00	26.40	20.30	19.95	18.00	26.20	16.20	39.00	63.85	75.50	S5(PN20)
32X20(40*25)	49.70	40.35	39.90	38.00	31.10	25.30	24.95	23.00	26.20	18.70	40.70	65.55	80.60	S5(PN20)
32X25(40*32)	49.70	40.35	39.90	38.00	39.70	32.30	31.90	30.00	26.20	22.20	43.70	68.55	87.40	S5(PN20)
40X15(50*20)	61.90	50.35	49.90	48.00	26.30	20.30	19.95	18.00	31.20	16.20	45.20	76.15	85.40	S5(PN20)
40X20(50*25)	61.90	50.35	49.90	48.00	31.80	25.30	24.95	23.00	31.20	18.70	46.70	77.65	90.20	S5(PN20)
40X25(50*32)	61.90	50.35	49.90	48.00	39.90	32.30	31.90	30.00	31.20	22.20	49.50	80.45	97.40	S5(PN20)
40X32(50*40)	61.90	50.35	49.90	48.00	49.30	40.35	39.90	38.00	31.20	26.20	52.70	83.65	65.25	S5(PN20)
50X15(63*20)	77.90	63.40	62.90	61.00	26.60	20.30	19.95	18.00	37.70	16.20	53.20	92.15	98.25	S5(PN20)
50X20(63*25)	77.90	63.40	62.90	61.00	31.80	25.30	24.95	23.00	37.70	18.70	54.70	93.65	103.10	S5(PN20)
50X25(63*32)	77.90	63.40	62.90	61.00	40.00	32.30	31.90	30.00	37.70	22.20	57.20	96.15	110.40	S5(PN20)
50X32(63*40)	77.90	63.40	62.90	61.00	49.70	40.35	39.90	38.00	37.70	26.20	59.20	98.15	118.40	S5(PN20)
50X40(63*50)	77.90	63.40	62.90	61.00	61.50	50.35	49.90	48.00	37.70	31.20	64.20	103.15	127.70	S5(PN20)
65X15(75*20)	91.20	75.40	74.90	70.90	26.30	20.30	19.95	18.00	43.70	16.20	55.20	100.8	140.00	S6.3(PN16)
65X20(75*25)	91.20	75.40	74.90	70.90	31.80	25.30	24.95	23.00	43.70	18.70	57.70	103.3	140.00	S6.3(PN16)
65X25(75*32)	91.20	75.40	74.90	70.90	39.90	32.30	31.90	23.00	43.70	22.20	61.20	106.8	140.30	S6.3(PN16)
65X32(75*40)	91.20	75.40	74.90	70.90	49.70	40.35	39.90	30.00	43.70	26.20	65.20	110.8	140.00	S6.3(PN16)
65X40(75*50)	91.20	75.40	74.90	70.90	61.50	50.35	49.90	48.00	43.70	31.20	70.20	115.2	140.00	S6.3(PN16)
65X50(75*63)	91.20	75.40	74.90	70.90	77.30	63.40	62.90	61.00	43.70	37.70	77.30	122.9	152.20	S6.3(PN16)
80X20(90*25)	107.60	90.50	89.90	85.90	31.80	25.30	24.95	23.00	51.20	18.70	65.20	119	167.80	S6.3(PN16)
80X25(90*32)	107.60	90.50	89.90	85.90	39.90	32.30	31.90	23.00	51.20	22.20	68.70	122.5	168.20	S6.3(PN16)
80X32(90*40)	107.60	90.50	89.90	85.90	49.50	40.35	39.90	38.00	51.20	26.20	72.70	126.5	168.20	S6.3(PN16)
80X40(90*50)	107.60	90.50	89.90	85.90	61.90	50.35	49.90	48.00	51.20	31.20	77.70	131.5	168.00	S6.3(PN16)
80X50(90*63)	107.60	90.50	89.90	85.90	77.30	63.40	62.90	61.00	51.20	37.70	84.20	138	168.20	S6.3(PN16)
80X65(90*75)	107.60	90.50	89.90	85.90	91.20	75.40	74.90	70.90	51.20	43.70	92.30	146.1	180.70	S6.3(PN16)
100X20(110*25)	127.00	110.60	109.90	103.90	31.80	25.30	24.95	23.00	61.20	18.70	74.20	137.7	189.00	S6.3(PN16)
100X25(110*32)	127.00	110.60	109.90	103.90	40.10	32.30	31.90	23.00	61.20	22.20	77.70	141.2	190.00	S6.3(PN16)
100X32(110*40)	127.00	110.60	109.90	103.90	49.70	40.35	39.90	38.00	61.20	26.20	81.70	145.2	190.50	S6.3(PN16)
100X40(110*50)	127.00	110.60	109.90	103.90	61.90	50.35	49.90	48.00	61.20	31.20	86.70	150.2	189.00	S6.3(PN16)
100X50(110*63)	127.00	110.60	109.90	103.90	77.30	63.40	62.90	61.00	61.20	37.70	93.20	156.7	190.00	S6.3(PN16)
100X65(110*75)	127.00	110.60	109.90	103.90	91.20	75.40	74.90	70.90	61.20	43.70	99.00	162.5	201.50	S6.3(PN16)
100X80(110*90)	127.00	110.60	109.90	103.90	107.60	90.50	89.90	85.90	61.20	51.20	110.35	173.85	214.80	S6.3(PN16)
De125*110	144.30	125.70	124.90	118.90	127.00	110.60	109.90	103.90	68.70	61.20	127.80	199.95	251.00	S6.3(PN16)
125X40(140*50)	161.60	140.75	139.90	133.90	61.60	50.35	49.90	48.00	76.20	31.20	101.70	182.5	247.40	S6.3(PN16)
125X50(140*63)	161.60	140.75	139.90	133.90	77.30	63.40	62.90	61.00	76.20	37.70	108.20	189	247.00	S6.3(PN16)
125X65(140*75)	161.60	140.75	139.90	133.90	91.20	75.40	74.90	70.90	76.20	43.70	114.00	194.8	248.00	S6.3(PN16)
125X80(140*90)	161.60	140.75	139.90	133.90	107.40	90.50	89.90	85.90	76.20	51.20	121.50	202.3	247.00	S6.3(PN16)
125X100(140*110)	161.60	140.75	139.90	133.90	127.00	110.60	109.90	103.90	76.20	61.20	136.70	217.5	266.40	S6.3(PN16)
De140*125	161.60	140.75	139.90	133.90	144.30	125.70	124.90	118.90	76.20	68.70	142.40	223.2	280.50	S6.3(PN16)
150X50(160*63)	184.60	160.80	159.90	153.90	77.70	63.40	62.90	61.00	86.20	37.70	118.20	210.5	286.00	S6.3(PN16)
150X65(160*75)	184.60	160.80	159.90	153.90	89.90	75.40	74.90	70.90	86.20	43.70	124.00	216.3	285.00	S6.3(PN16)
150X80(160*90)	184.60	160.80	159.90	153.90	107.60	90.50	89.90	85.90	86.20	51.20	131.50	223.8	285.50	S6.3(PN16)
150X100(160*110)	184.60	160.80	159.90	153.90	127.30	110.60	109.90	103.90	86.20	61.20	142.50	234.8	286.00	S6.3(PN16)
150X125(160*140)	184.60	160.80	159.90	153.90	161.80	140.75	139.90	133.90	86.20	76.20	161.50	253.8	315.50	S6.3(PN16)
De180*160	202.60	180.80	180.10	178.50	184.60	160.80	159.90	153.90	97.00	86.20	180.00	281.3	326.00	S6.3(PN16)
De200*90	230.50	201.00	199.90	193.50	107.70	90.50	89.90	85.90	106.20	51.20	151.50	266.75	356.50	S6.3(PN16)
De200*110	230.50	201.00	199.90	193.50	127.50	110.60	109.90	103.90	106.20	61.20	162.50	277.75	357.00	S6.3(PN16)
De200*140	230.50	201.00	199.90	193.50	162.20	140.75	139.90	133.90	106.20	76.20	178.00	293.25	356.50	S6.3(PN16)
De200*160	230.50	201.00	199.90	193.50	184.60	160.80	159.90	153.90	106.20	86.20	197.50	312.75	415.50	S6.3(PN16)
200X50(225*63)	259.40	226.20	224.90	216.90	77.30	63.40	62.90	61.00	119.10	37.70	149.70	279.4	384.00	S6.3(PN16)

200X65(225*75)	259.40	226.20	224.90	216.90	91.20	75.40	74.90	70.90	119.10	43.70	155.50	285.2	384.00	S6.3(PN16)
200X80(225*90)	259.40	226.20	224.90	216.90	107.60	90.50	89.90	85.90	119.10	51.20	163.00	292.7	384.00	S6.3(PN16)
200X100(225*110)	259.40	226.20	224.90	216.90	127.00	110.60	109.90	103.90	119.10	61.20	174.00	303.7	384.00	S6.3(PN16)
200X125(225*140)	259.40	226.20	224.90	216.90	161.90	140.75	139.90	133.90	119.10	76.20	189.50	319.2	384.00	S6.3(PN16)
200X150(225*160)	259.40	226.20	224.90	216.90	185.00	160.80	159.90	153.90	119.10	86.20	209.70	339.4	403.00	S6.3(PN16)
De225*200	259.40	226.20	224.90	216.90	230.50	201.00	199.90	193.50	119.10	106.20	231.50	361.2	384.00	S6.3(PN16)
De250*63	281.10	251.30	249.90	241.90	77.30	63.40	62.90	61.00	132.00	37.70	162.00	302.55	429.50	S8(PN16)
De250*75	281.10	251.30	249.90	241.90	91.20	75.40	74.90	70.90	132.00	43.70	167.80	308.35	429.50	S8(PN16)
De250*90	281.10	251.30	249.90	241.90	107.80	90.50	89.90	85.90	132.00	51.20	175.30	315.85	429.50	S8(PN16)
De250*110	281.10	251.30	249.90	241.90	127.00	110.60	109.90	103.90	132.00	61.20	186.30	326.85	429.50	S8(PN16)
De250*140	281.10	251.30	249.90	241.90	161.60	140.75	139.90	133.90	132.00	76.20	201.80	342.35	429.50	S8(PN16)
De250*160	281.10	251.30	249.90	241.90	184.60	160.80	159.90	178.50	132.00	86.20	211.80	352.35	429.50	S8(PN16)
De250*225	287.90	251.30	249.90	241.90	259.40	226.20	224.90	218.90	132.00	119.10	254.00	397.95	429.50	S8(PN16)
De280*225	314.80	281.50	279.90	278.00	259.20	226.20	224.90	218.90	147.00	132.00	276.00	433.40	526.50	S8(PN16)
300X80(315*90)	354.70	316.70	314.90	306.90	107.60	90.50	89.90	85.90	164.30	51.20	198.70	376.05	445.90	S8(PN16)
300X100(315*110)	354.70	316.70	314.90	306.90	127.00	110.60	109.90	103.90	164.30	61.20	209.70	387.05	600.10	S8(PN16)
300X125(315*140)	354.70	316.70	314.90	306.90	161.60	140.75	139.90	133.90	164.30	76.20	225.20	402.55	600.10	S8(PN16)
300X150(315*160)	354.70	316.70	314.90	306.90	184.60	160.80	159.90	153.90	164.30	86.20	235.20	412.55	600.10	S8(PN16)
De315*200	354.70	316.70	314.90	306.90	230.50	201.00	199.90	193.50	164.30	106.20	268.50	445.85	600.10	S8(PN16)
300X200(315*225)	354.70	316.70	314.90	306.90	259.40	226.20	224.90	220.90	164.30	119.10	269.20	446.55	600.10	S8(PN16)
De315*250	354.70	316.70	314.90	306.90	288.60	251.30	249.90	241.90	164.30	132.00	282.00	459.35	644.00	S8(PN16)
300X250(315*280)	391.00	316.70	314.90	306.90	314.50	281.50	279.90	278.00	164.30	147.00	321.50	517.00	647.00	S8(PN16)
De355*200	388.00	356.80	355.00	326.00	230.50	201.00	199.90	193.50	184.30	106.20	285.50	478.00	590.50	PN6
350X225(355*250)	388.00	356.80	355.00	326.00	281.10	251.30	249.90	241.90	184.30	132.00	311.50	504.60	639.00	PN6
350X300(355*315)	388.00	356.80	400.00	326.00	344.20	316.70	314.90	306.90	184.30	164.30	350.60	544.60	693.00	PN6
De400*200	432.70	401.60	400.00	398.50	220.90	200.90	199.85	197.00	107.00	208.00	318.60	534.95	623.00	PN6
400X225(400*250)	432.40	401.60	400.00	398.50	273.50	251.15	249.41	247.00	132.00	208.00	342.80	559.00	672.00	PN6
400X300(400*315)	432.70	401.60	400.00	398.50	344.50	316.55	315.05	312.00	165.00	208.00	370.00	586.35	752.00	PN6

COPPER THREADED ELBOW 90°

铜内丝 90°弯头, PVC-U/C (国标)

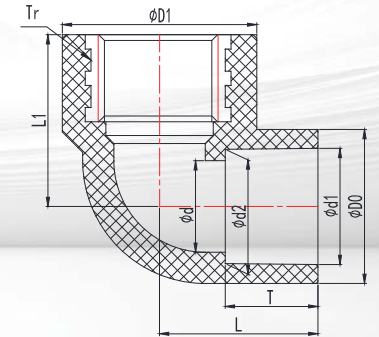

产品参数 (美标 ASTM SCH80)

尺寸 Size (*")	外形尺寸 Dimensions (mm)											
	D0	D1	D2	D3	d0	d1	d2	d3	t	T	H	L
3/4"×1/2"	35.87	26.87	26.57	22.50	30.14	21.54	21.23	17.00	23.22	26.40	38.55	82.80
1"×1/2"	44.30	33.66	33.27	29.00	30.14	21.54	21.23	17.00	23.22	29.57	41.75	94.20
1"×3/4"	44.30	33.66	33.27	29.00	35.87	26.87	26.57	22.50	26.40	29.57	44.60	94.20
1-1/4"×3/4"	53.42	42.42	42.04	38.00	35.87	26.87	26.57	22.50	26.40	32.75	49.10	111.50
1-1/4"×1"	53.42	42.42	42.04	38.00	44.30	33.66	33.27	29.00	29.57	32.75	51.60	111.50
1-1/2"×1"	60.40	48.56	48.11	43.00	44.30	33.66	33.27	29.00	29.57	35.93	54.35	124.00
1-1/2"×1-1/4"	60.40	48.56	48.11	43.00	53.42	42.42	42.04	38.00	32.75	35.93	58.50	124.00
2"×1-1/4"	73.10	60.63	60.17	55.00	53.42	42.42	42.04	38.00	32.75	39.10	64.00	141.70
2"×1-1/2"	73.10	60.63	60.17	55.00	60.40	48.56	48.11	43.00	35.93	39.10	67.45	141.70
2-1/2"×1-1/2"	88.40	73.38	72.85	67.50	60.40	48.56	48.11	43.00	35.93	45.45	73.70	169.00
2-1/2"×2"	88.40	73.38	72.85	67.50	73.10	60.63	60.17	55.00	39.10	45.45	77.10	169.00
3"×2"	105.70	89.31	88.70	83.00	73.10	60.63	60.17	55.00	39.10	48.63	84.60	194.15
3"×2-1/2"	105.70	89.31	88.70	83.00	88.40	73.38	72.85	67.50	45.45	48.63	92.00	194.15
4"×2-1/2"	132.50	114.76	114.07	106.00	88.40	73.38	72.85	67.50	45.45	58.15	103.00	234.50
4"×3"	132.50	114.76	114.07	106.00	105.70	89.31	88.70	83.00	48.63	58.15	107.65	234.50
5"×2"	161.60	141.81	141.04	133.00	72.70	60.63	60.17	55.00	39.10	67.68	105.10	285.60
6"×2"	192.00	168.83	168.00	160.00	73.10	60.63	60.17	55.00	39.10	77.20	128.85	332.50
6"×4"	192.00	168.83	168.00	160.00	132.50	114.76	114.07	106.00	58.15	77.20	144.25	332.50
8"×4"	246.50	219.84	218.69	208.00	132.50	114.76	114.07	106.00	58.15	102.60	162.75	435.20
8"×6"	246.50	219.84	218.69	208.00	192.00	168.83	168.00	160.00	77.20	102.60	190.25	435.20
10"×6"	305.80	273.81	272.67	262.50	192.00	168.83	168.00	160.00	77.20	128.00	217.50	446.60
10"×8"	305.80	273.81	272.67	262.50	246.50	219.84	218.69	208.00	102.60	128.00	245.00	496.50
12"×8"	361.60	324.60	323.47	313.00	246.50	219.84	218.69	208.00	102.60	153.40	269.30	583.00
12"×10"	361.60	324.60	323.47	313.00	305.80	273.81	272.67	262.50	128.00	153.40	296.80	656.80

尺寸 Size DN(De)	外形尺寸 Dimensions (mm)									公称压力 Nominal Pressure PN(kg/cm²)
	D0	D1	d1	d2	d	T	L1	L	Tr 螺纹	
15(20)	26.90	34.00	20.30	19.95	16.00	16.20	27.70	43.50	1/2"	S5(PN20)
20(25)	32.60	39.50	25.30	24.95	21.00	18.70	32.70	50.30	3/4"	S5(PN20)
25(32)	40.10	46.50	32.30	31.90	28.00	22.20	39.70	60.30	1"	S5(PN20)

PVC-U/C CROSS

正四通, PVC-U/C (国标, 美标)

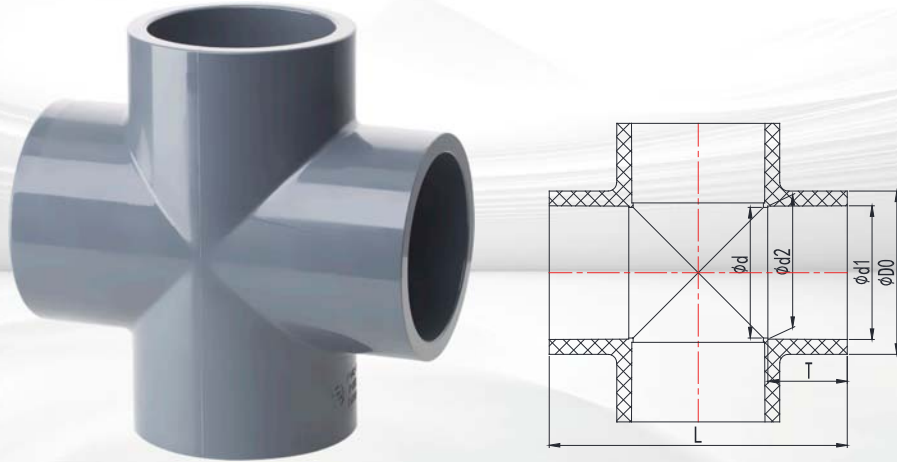

产品参数 (国标 DIN)

尺寸 Size DN	外形尺寸 Dimensions (mm)						公称压力 Nominal Pressure PN(kg/cm ²)
	D0	D1	D2	d	T	L	
15	26.30	20.30	19.95	18.00	16.20	55.40	S5(PN20)
20	31.80	25.30	24.95	21.00	18.70	65.40	S5(PN20)
25	39.90	32.30	31.90	28.00	22.20	79.40	S5(PN20)
32	49.50	40.35	39.90	36.00	26.20	95.40	S5(PN20)
40	61.50	50.35	49.90	46.00	31.20	115.40	S5(PN20)
50	77.40	63.40	62.90	59.00	37.70	141.00	S5(PN20)
65	91.20	75.40	74.90	70.90	43.70	165.00	S6.3(PN16)
80	107.60	90.50	89.90	85.90	51.20	194.50	S6.3(PN16)
100	127.00	110.60	109.90	103.90	61.20	234.50	S6.3(PN16)
De125	144.30	125.70	124.90	118.90	68.70	263.80	S6.3(PN16)
125	161.60	140.75	139.90	133.90	76.20	295.00	S6.3(PN16)
150	185.30	160.80	159.90	153.90	86.20	336.00	S6.3(PN16)
De200	230.00	201.00	199.90	193.90	106.20	414.00	S6.3(PN16)
200	259.40	226.20	224.90	216.90	119.10	465.00	S6.3(PN16)
De250	287.90	251.30	249.90	241.40	131.65	515.50	S6.3(PN16)
250	314.80	281.20	280.10	276.00	147.00	582.00	S8(PN16)
300	354.00	316.70	314.90	307.00	164.30	643.00	S8(PN16)

产品参数 (美标 ASTM SCH80)

尺寸 Size (*")	外形尺寸 Dimensions (mm)					
	D0	d1	d2	d	T	L
1/2"	29.54	21.54	21.23	17.00	23.22	72.50
3/4"	35.36	26.87	26.57	22.50	26.40	82.80
1"	43.66	33.66	33.27	29.00	29.57	94.20
1-1/4"	53.02	42.42	42.04	38.00	32.75	111.50
1-1/2"	59.86	48.56	48.11	43.00	35.93	124.00
2"	72.23	60.63	60.17	55.00	39.10	143.70
2-1/2"	88.00	73.38	72.85	67.50	45.45	169.00
3"	105.30	89.31	88.70	83.00	48.63	193.26
4"	132.00	114.76	114.07	106.00	58.15	234.50
5"	162.00	141.81	141.04	133.00	67.68	287.00
6"	190.85	168.83	168.00	160.00	77.20	332.50

PVC-U/C BUSHING

变径 (补芯), PVC-U/C (国标, 美标)

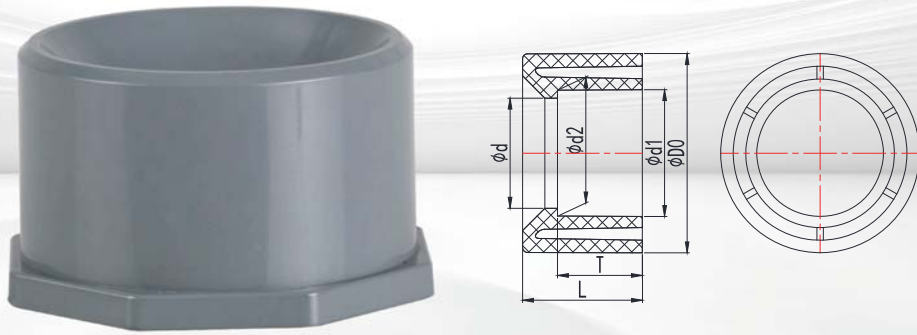

产品参数 (国标 DIN)

尺寸 Size DN(De)	外形尺寸 Dimensions (mm)					
	D0	d1	d2	d	T	L
20X15(25*20)	25.00	20.30	19.95	16.00	17.00	19.20
25X15(32*20)	32.00	20.30	19.95	16.00	17.00	22.20
25X20(32*25)	32.00	25.30	24.95	21.00	19.50	22.20
32X15(40*20)	40.00	20.30	19.95	16.00	17.00	26.30
32X20(40*25)	40.00	25.30	24.95	21.00	19.50	26.30
32X25(40*32)	40.00	32.30	31.90	27.50	23.00	26.30
40X15(50*20)	50.00	20.30	19.95	16.00	17.00	31.20
40X20(50*25)	50.00	25.30	24.95	21.00	19.50	31.20
40X25(50*32)	50.00	32.30	31.90	27.50	23.00	31.20
40X32(50*40)	50.00	40.35	39.90	35.00	27.00	31.20
50X15(63*20)	63.00	20.30	19.95	16.00	17.00	38.10
50X20(63*25)	63.00	25.30	24.95	21.00	19.50	38.10
50X25(63*32)	63.00	32.30	31.90	27.50	23.00	38.10
50X32(63*40)	63.00	40.35	39.90	35.00	27.00	38.10
50X40(63*50)	63.00	50.35	49.90	45.00	32.00	38.10
65X20(75*25)	75.00	25.30	24.95	21.00	19.50	44.10
65X25(75*32)	75.00	32.30	31.90	27.50	23.00	44.10
65X32(75*40)	75.00	40.35	39.90	35.00	27.00	44.10
65X40(75*50)	75.00	50.35	49.90	45.00	32.00	44.10
65X50(75*63)	75.00	63.40	62.90	56.00	38.50	44.10
80X25(90*32)	90.00	32.30	31.90	27.50	23.00	51.00
80X32(90*40)	90.00	40.35	39.90	35.00	27.00	51.00
80X40(90*50)	90.00	50.35	49.90	45.00	32.00	51.00
80X50(90*63)	90.00	63.40	62.90	56.00	38.50	51.00
80X65(90*75)	90.00	75.40	74.90	67.00	44.50	51.00
100X40(110*50)	110.00	50.35	49.90	45.00	32.00	61.00
100X50(110*63)	110.00	63.40	62.90	56.00	38.50	61.00
100X65(110*75)	110.00	75.40	74.90	67.00	44.50	61.00
100X80(110*90)	110.00	90.50	89.90	80.50	52.00	61.00
De125*110	125.00	110.40	109.90	102.00	62.00	68.70
125X50(140*63)	140.00	63.40	62.90	102.00	62.00	77.00
125X65(140*75)	140.00	75.40	74.90	117.00	68.70	76.20
125X80(140*90)	140.00	90.50	89.90	56.00	38.50	76.20
125X100(140*110)	140.00	110.60	109.90	67.00	44.50	76.20
De140*125	140.00	125.70	124.90	80.50	52.00	76.20
150X50(160*63)	160.00	63.40	62.90	96.00	62.00	86.00
150X65(160*75)	160.00	75.40	74.90	130.00	77.00	86.00
150X80(160*90)	160.00	90.50	89.90	56.00	38.50	86.00
150X100(160*110)	160.00	110.60	109.90	67.00	44.50	86.00
150X125(160*140)	160.00	125.70	139.90	80.50	52.00	86.00
De180*160	180.00	160.80	159.90	150.90	86.20	96.00
De200*160	200.00	160.80	159.90	151.50	85.50	106.50
De200*180	200.00	180.90	179.90	169.70	96.00	106.20
200X100(225*110)	225.00	110.60	109.90	96.00	62.00	118.70
200X125(225*140)	225.00	140.75	139.90	130.00	77.00	118.70
200X150(225*160)	225.00	160.80	159.90	150.50	85.50	118.70
De225*200	225.00	201.00	199.90	188.80	106.20	118.70
De250*110	250.00	110.60	109.90	96.00	62.00	131.20
De250*160	250.00	160.80	159.90	150.50	85.50	131.20
De250*200	250.00	201.00	199.90	188.80	106.20	131.20
De250*225	250.00	226.20	224.90	210.80	119.10	131.20
250X200(280*225)	280.00	226.20	224.90	208.80	119.10	146.20

300X100(315*110)	315.00	110.60	109.90	96.00	62.00	163.70
300X150(315*160)	315.00	160.80	159.90	150.50	85.50	163.70
De315*200	315.00	201.00	199.90	188.80	106.20	163.70
300X200(315*225)	315.00	226.20	224.90	210.80	119.10	163.70
De315*250	315.00	251.15	249.90	239.00	131.65	163.70
300X250(315*280)	315.00	281.50	279.90	263.50	146.20	163.70
De355*200	355.00	201.00	199.90	188.80	106.20	183.70
350X200(355*225)	355.00	226.20	224.90	210.80	119.10	183.70
De355*250	355.00	251.15	249.90	239.00	131.65	183.70
350X300(355*315)	355.00	316.55	314.90	305.00	164.30	183.70
De400*200	400.00	201.00	199.90	188.80	106.20	206.20
400X200(400*225)	400.00	226.20	224.90	210.80	119.10	206.20
De400*250	400.00	251.15	249.90	239.00	131.65	206.20
400X300(400*315)	400.00	316.60	314.90	305.00	164.30	206.20
400X350(400*355)	400.00	356.70	354.90	345.00	183.70	206.20

产品参数 (美标 ASTM SCH80)

尺寸 Size (*")	外形尺寸 Dimensions (mm)						
	D0	D1	D2	D3	d0	d1	d2
1/2"*1/4"	21.34	14.02	13.60	10.00	16.50	23.50	29.00
1/2"*3/8"	21.34	17.45	17.04	12.00	19.50	23.50	29.00
3/4"*1/2"	26.67	21.54	21.23	17.00	23.22	26.40	31.90
1"*3/8"	33.40	17.45	17.04	12.00	19.50	29.58	35.58
1"*1/2"	33.40	21.54	21.23	17.00	23.22	29.58	35.58
1"*3/4"	33.40	26.87	26.57	22.50	26.40	29.58	35.58
1-1/4"*1/2"	42.16	21.54	21.23	17.00	23.22	30.00	36.00
1-1/4"*3/4"	42.16	26.87	26.57	22.50	26.40	30.00	36.00
1-1/4"*1"	42.16	33.66	33.27	29.00	29.57	30.00	36.00
1-1/2"*1/2"	48.26	21.54	21.23	17.00	23.22	35.93	41.93
1-1/2"*3/4"	48.26	26.87	26.57	22.50	26.40	35.93	41.93
1-1/2"*1"	48.26	33.66	33.27	29.00	29.57	35.93	41.93
1-1/2"*1-1/4"	48.26	42.42	42.04	38.00	32.75	35.93	41.93
2"*1/2"	60.33	21.54	21.23	17.00	23.22	39.10	45.10
2"*3/4"	60.33	26.87	26.57	22.50	26.40	39.10	45.10
2"*1"	60.33	33.66	33.27	29.00	29.57	39.10	45.10
2"*1-1/4"	60.33	42.42	42.04	38.00	32.75	39.10	45.10
2"*1-1/2"	60.33	48.56	48.11	43.00	35.93	39.10	45.10
2-1/2"*1-1/2"	70.03	48.56	48.11	43.00	35.93	45.00	51.00
2-1/2"*2"	70.03	60.63	60.17	55.00	39.10	45.00	51.00
3"*1-1/2"	88.90	48.56	48.11	43.00	35.93	49.00	57.00
3"*2"	88.90	60.63	60.17	55.00	39.10	49.00	57.00
3"*2-1/2"	88.90	48.56	48.11	67.50	35.93	49.00	57.00
4"*2"	114.30	60.63	60.17	55.00	39.10	59.00	67.00
4"*2-1/2"	114.30	48.56	48.11	67.50	35.93	59.00	67.00
4"*3"	114.30	89.31	88.70	83.00	48.63	59.00	67.00
5"*4"	141.30	114.76	114.07	106.00	58.15	69.00	79.00
6"*3"	168.30	89.31	88.70	83.00	48.63	78.00	90.00
6"*4"	168.30	114.76	114.07	106.00	58.15	78.00	90.00
6"*5"	168.30	141.81	141.04	133.00	67.68	78.00	90.00
8"*4"	219.10	114.76	114.07	106.00	58.15	103.00	115.00
8"*6"	219.10	168.83	168.00	160.00	77.20	103.00	115.00
10"*3"	273.05	89.31	88.70	83.00	48.63	127.00	148.00
10"*4"	273.05	114.76	114.07	106.00	58.15	127.00	148.00
10"*6"	273.05	168.83	168.00	160.00	77.20	127.00	148.00
10"*8"	273.05	219.84	218.69	208.00	102.60	127.00	148.00
12"*4"	323.85	114.76	114.07	106.00	58.15	151.00	169.00
12"*6"	323.85	168.83	168.00	160.00	77.20	151.00	169.00
12"*8"	323.85	219.84	218.69	208.00	102.60	151.00	169.00
12"*10"	323.85	273.81	272.67	262.50	128.00	151.00	169.00

PVC-U/C
COPPER THREADED TEE
铜内丝三通, PVC-U/C (国标)

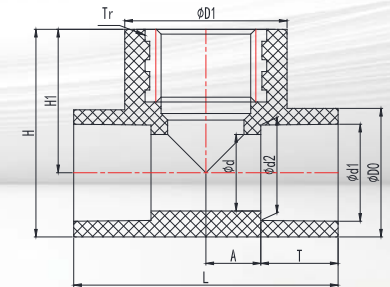

尺寸 Size DN	外形尺寸 Dimensions (mm)										公称压力 Nominal Pressure PN(kg/cm ²)
	D0	D1	d1	d2	d	T	H1	H	L	Tr 螺纹	
15	26.90	34.00	20.30	19.95	16.00	16.20	30.00	43.45	55.40	1/2"	S5(PN20)
20	32.60	39.50	25.30	24.95	21.00	18.70	34.00	50.30	65.40	3/4"	S5(PN20)
25	40.10	46.50	32.30	31.90	28.00	22.20	40.00	60.05	79.40	1"	S5(PN20)

PVC-U/C REDUCER

异径, PVC-U/C (国标, 美标)

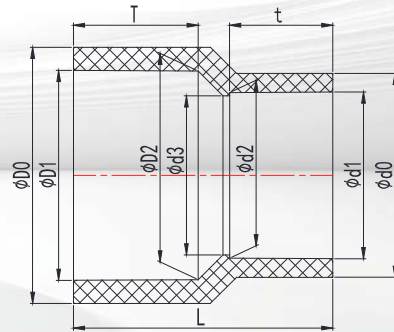

产品参数 (国标 DIN)

尺寸 Size DN(De)	外形尺寸 Dimensions (mm)										公称压力 Nominal Pressure PN(kg/cm ²)
	D0	D1	D2	d0	d1	d2	d3	t	T	L	
20X15(25*20)	31.80	25.30	24.95	26.30	20.30	19.95	18.00	16.20	18.70	40.00	S5(PN20)
25X15(32*20)	39.90	32.30	31.90	26.30	20.30	19.95	18.00	16.20	22.20	48.50	S5(PN20)
25X20(32*25)	39.90	32.30	31.90	31.80	25.30	24.95	23.00	18.70	22.20	47.40	S5(PN20)
32X15(40*20)	49.40	40.35	39.90	26.30	20.30	19.95	18.00	16.20	26.20	56.50	S5(PN20)
32X20(40*25)	49.30	40.35	39.90	31.80	25.30	24.95	23.00	18.70	26.20	56.80	S5(PN20)
32X25(40*32)	49.40	40.35	39.90	39.70	32.30	31.90	30.00	22.20	26.20	54.80	S5(PN20)
40X15(50*20)	61.50	50.35	49.90	26.30	20.30	19.95	18.00	16.20	31.20	66.00	S5(PN20)
40X20(50*25)	61.50	50.35	49.90	31.80	25.30	24.95	23.00	18.70	31.20	66.00	S5(PN20)
40X25(50*32)	61.50	50.35	49.90	39.90	32.30	31.90	30.00	22.20	31.20	67.00	S5(PN20)
40X32(50*40)	61.90	50.35	49.90	49.70	40.35	39.90	38.00	26.20	31.20	65.00	S5(PN20)
50X15(63*20)	77.20	63.40	62.90	26.30	20.30	19.95	18.00	16.20	37.70	79.00	S5(PN20)
50X20(63*25)	77.30	63.40	62.90	31.80	25.30	24.95	23.00	18.70	37.70	79.00	S5(PN20)
50X25(63*32)	77.90	63.40	62.90	39.90	32.30	31.90	30.00	22.20	37.70	80.00	S5(PN20)
50X32(63*40)	77.30	63.40	62.90	49.70	40.35	39.90	38.00	26.20	37.70	80.00	S5(PN20)
50X40(63*50)	77.30	63.40	62.90	61.90	50.35	49.90	48.00	31.20	37.70	77.70	S5(PN20)
65X15(75*20)	90.80	75.40	74.90	26.30	20.30	19.95	18.00	16.20	43.70	93.00	S6.3(PN16)
65X20(75*25)	90.80	75.40	74.90	31.80	25.30	24.95	23.00	18.70	43.70	92.70	S6.3(PN16)
65X25(75*32)	90.80	75.40	74.90	39.90	32.30	31.90	30.00	22.20	43.70	93.50	S6.3(PN16)
65X32(75*40)	90.80	75.40	74.90	49.40	40.35	39.90	38.00	26.20	43.70	93.00	S6.3(PN16)
65X40(75*50)	91.00	75.40	74.90	61.70	50.35	49.90	48.00	31.20	43.70	93.30	S6.3(PN16)
65X50(75*63)	91.00	75.40	74.90	77.50	63.40	62.90	61.00	37.70	43.70	92.50	S6.3(PN16)
80X20(90*25)	107.30	90.50	89.90	32.00	25.30	24.95	23.00	18.70	51.20	108.00	S6.3(PN16)
80X25(90*32)	107.20	90.50	89.90	40.40	32.30	31.90	30.00	22.20	51.20	108.10	S6.3(PN16)
80X32(90*40)	107.20	90.50	89.90	49.70	40.35	39.90	38.00	26.20	51.20	108.50	S6.3(PN16)
80X40(90*50)	107.30	90.50	89.90	61.60	50.35	49.90	48.00	31.20	51.20	108.20	S6.3(PN16)
80X50(90*63)	107.30	90.50	89.90	77.30	63.40	62.90	61.00	37.70	51.20	108.00	S6.3(PN16)
80X65(90*75)	107.30	90.50	89.90	91.20	75.40	74.90	70.90	43.70	51.20	107.30	S6.3(PN16)
100X20(110*25)	127.00	110.60	109.90	32.00	25.30	24.95	23.00	18.70	61.20	127.80	S6.3(PN16)
100X25(110*32)	127.00	110.60	109.90	40.10	32.30	31.90	30.00	22.20	61.20	128.30	S6.3(PN16)
100X32(110*40)	126.80	110.60	109.90	49.70	40.35	39.90	38.00	26.20	61.20	128.60	S6.3(PN16)
100X40(110*50)	127.00	110.60	109.90	61.70	50.35	49.90	48.00	31.20	61.20	128.00	S6.3(PN16)
100X50(110*63)	127.40	110.60	109.90	77.50	63.40	62.90	61.00	37.70	61.20	128.00	S6.3(PN16)
100X65(110*75)	127.00	110.60	109.90	90.80	75.40	74.90	70.90	43.70	61.20	128.60	S6.3(PN16)
100X80(110*90)	127.00	110.60	109.90	107.30	90.50	89.90	85.90	51.20	61.20	127.40	S6.3(PN16)
De125*110	144.00	125.70	124.90	127.00	110.60	109.90	103.90	61.20	68.70	142.60	S6.3(PN16)
125X40(140*50)	161.60	140.75	139.90	61.60	50.30	49.90	48.00	31.11	76.20	157.60	S6.3(PN16)
125X50(140*63)	161.60	140.75	139.90	77.60	63.40	62.90	61.00	37.59	76.20	158.00	S6.3(PN16)
125X65(140*75)	161.60	140.75	139.90	91.00	75.35	74.90	70.90	43.57	76.20	158.50	S6.3(PN16)
125X80(140*90)	161.70	140.75	139.90	77.50	90.50	89.90	85.90	52.00	76.20	158.30	S6.3(PN16)
125X100(140*110)	161.80	140.75	139.90	127.20	110.60	109.90	103.90	61.02	76.20	157.70	S6.3(PN16)
De140*125	161.80	140.75	139.90	144.60	125.65	124.90	118.90	68.70	76.20	157.50	S6.3(PN16)
150X50(160*63)	184.60	160.70	159.90	127.00	63.35	62.90	61.00	37.82	87.00	180.50	S6.3(PN16)
150X65(160*75)	184.60	160.70	159.90	91.20	75.35	74.90	70.90	43.83	87.00	179.00	S6.3(PN16)

150X80(160*90)	184.60	160.70	159.90	107.70	90.50	89.90	85.90	51.36	87.00	178.70	S6.3(PN16)
150X100(160*110)	184.60	160.70	159.90	127.50	110.60	109.90	103.90	61.40	87.00	180.20	S6.3(PN16)
150X125(160*140)	184.60	160.70	159.90	161.90	140.75	139.90	133.90	77.00	87.00	177.30	S6.3(PN16)
De180*160	202.60	180.80	179.90	180.00	160.70	159.90	153.90	87.00	97.00	202.20	S6.3(PN16)
De200*160	230.00	201.00	199.90	184.00	160.80	159.90	153.90	86.20	106.20	217.50	S6.3(PN16)
200X150(225*160)	259.40	226.20	224.90	184.00	160.80	159.90	153.90	86.20	119.10	242.50	S6.3(PN16)
De225*200	259.40	226.20	224.90	230.50	201.00	199.90	193.50	106.20	119.10	243.00	S6.3(PN16)
De250*225	287.90	251.30	249.90	259.00	226.20	224.90	216.90	119.10	131.65	269.50	S8(PN16)
250X200(280*225)	314.80	281.30	279.90	259.40	226.20	224.90	216.90	119.10	147.00	304.50	S8(PN16)
300X250(315*280)	354.60	316.60	314.90	314.80	281.30	279.90	278.00	147.00	164.30	338.00	S8(PN16)
350X300(355*315)	391.00	356.80	355.00	354.60	316.60	314.90	306.90	164.30	184.30	384.00	PN6
400X300(400*315)	442.00	402.00	400.00	344.00	316.60	314.90	306.90	164.30	207.00	435.00	PN6
400X350(400*355)	442.00	402.00	400.00	384.25	356.80	355.00	326.00	184.30	207.00	430.70	PN6

产品参数 (美标 ASTM SCH80)

尺寸 Size (*")	外形尺寸 Dimensions (mm)									
	D0	D1	D2	d0	d1	d2	d3	t	T	L
3/4"*1/2"	36.90	26.87	26.57	30.50	21.54	21.23	17.00	23.22	26.40	58.60
1"*1/2"	44.70	33.66	33.27	30.50	21.54	21.23	17.00	23.22	29.57	65.10
1"*3/4"	44.70	33.66	33.27	36.90	26.87	26.57	22.50	26.40	29.57	66.30
1-1/4"*1/2"	54.00	42.42	42.04	30.50	21.54	21.23	17.00	23.22	32.75	72.68
1-1/4"*3/4"	54.00	42.42	42.04	36.90	26.87	26.57	22.50	26.40	32.75	73.80
1-1/4"*1"	54.00	42.42	42.04	44.70	33.66	33.27	29.00	29.57	32.75	73.80
1-1/2"*3/4"	60.60	48.56	48.11	36.90	26.87	26.57	22.50	26.40	35.93	80.00
1-1/2"*1"	60.60	48.56	48.11	40.70	33.66	33.27	29.00	29.57	35.93	80.00
1-1/2"*1-1/4"	60.60	48.56	48.11	54.00	42.42	42.04	38.00	32.75	35.93	78.70
2"*1"	73.10	60.63	60.17	44.70	33.66	33.27	29.00	29.57	39.10	88.20
2"*1-1/4"	73.10	60.63	60.17	54.00	42.42	42.04	38.00	32.75	39.10	88.20
2"*1-1/2"	73.10	60.63	60.17	60.60	48.56	48.11	43.00	35.93	39.10	88.50
10"*8"	305.00	273.81	272.67	245.90	219.84	218.69	208.00	102.60	128.00	269.75

PVC-U/C
COPPER THREADED REDUCER

铜内丝直接, PVC-U/C (国标)

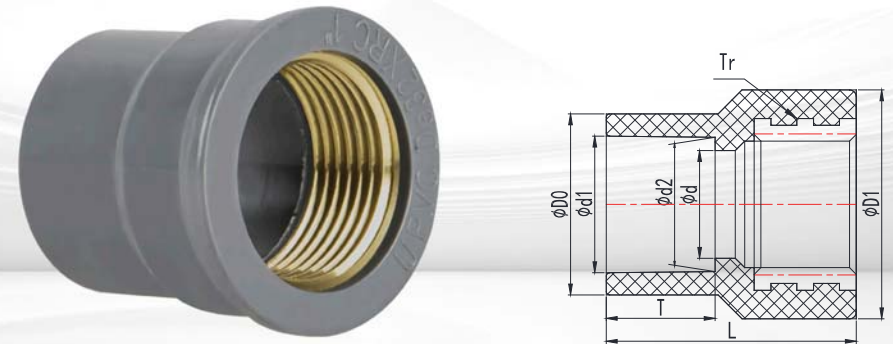

尺寸 Size DN	外形尺寸 Dimensions (mm)								公称压力 Nominal Pressure PN(kg/cm ²)
	D0	D1	d1	d2	T	d	L	Tr 螺纹	
15	26.90	34.00	20.30	19.95	16.20	16.00	37.20	1/2"	S5(PN20)
20	32.60	39.50	25.30	24.95	18.70	21.00	40.70	3/4"	S5(PN20)
25	40.10	46.50	32.30	31.90	22.20	28.00	47.90	1"	S5(PN20)

EXPERT IN PIPING SYSTEM

管路系统的专家级工厂



PVC-U/C CAP

管堵, PVC-U/C (国标, 美标)

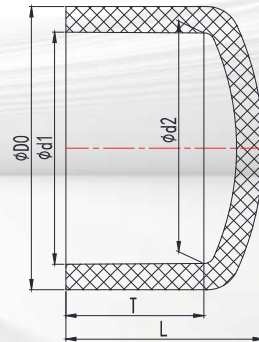

产品参数 (国标 DIN)

尺寸 Size DN	外形尺寸 Dimensions (mm)					公称压力 Nominal Pressure PN(kg/cm ²)
	D0	d1	d2	T	L	
15	26.30	20.30	19.95	16.20	21.90	S5(PN20)
20	31.80	25.30	24.95	18.70	25.70	S5(PN20)
25	39.90	32.30	31.90	22.20	30.70	S5(PN20)
32	49.70	40.40	39.90	26.20	36.90	S5(PN20)
40	61.90	50.40	49.90	31.20	44.70	S5(PN20)
50	77.90	63.40	62.90	37.70	54.00	S5(PN20)
65	91.20	75.40	74.90	43.70	62.60	S6.3(PN16)
80	107.60	90.50	89.90	51.20	73.30	S6.3(PN16)
100	127.00	110.60	109.90	61.20	84.50	S6.3(PN16)
De125	144.30	125.70	124.90	68.70	96.10	S6.3(PN16)
125	161.60	140.80	139.90	76.20	109.70	S6.3(PN16)
150	184.60	160.80	159.90	86.20	126.20	S6.3(PN16)
De180	202.60	180.90	179.90	97.00	142.90	S6.3(PN16)
De200	230.50	201.00	199.90	106.20	151.10	S6.3(PN16)
200	259.40	226.20	224.90	119.10	170.40	S6.3(PN16)
De250	287.90	251.30	249.90	131.65	186.90	S8(PN16)
250	314.80	281.50	279.90	147.00	212.50	S8(PN16)
300	358.20	316.70	314.90	164.30	234.50	S8(PN16)
350	391.00	356.80	355.00	184.30	265.00	PN6
400	442.00	402.00	400.00	204.20	294.00	PN6

产品参数 (美标 ASTM SCH80)

尺寸 Size (*")	外形尺寸 Dimensions (mm)				
	D0	d1	d2	T	L
1/2"	29.54	21.54	21.23	23.22	30.80
3/4"	35.31	26.87	26.57	26.40	35.13
1"	43.70	33.66	33.27	29.57	40.00
1-1/4"	53.05	42.42	42.04	32.75	45.00
1-1/2"	59.86	48.56	48.11	35.93	49.00
2"	72.23	60.63	60.17	39.10	53.95
2-1/2"	87.98	73.38	72.85	45.45	64.20
3"	105.30	89.31	88.70	48.63	58.00
4"	132.00	114.76	114.07	58.15	81.00
5"	161.80	141.81	141.04	67.68	106.50
6"	190.85	168.83	168.00	77.20	119.55
8"	245.85	219.84	218.69	102.60	141.70
10"	305.80	273.81	272.67	128.00	186.25
12"	361.60	324.60	323.47	153.40	228.00

PVC-U/C COUPLING

管箍, PVC-U/C (国标, 美标)

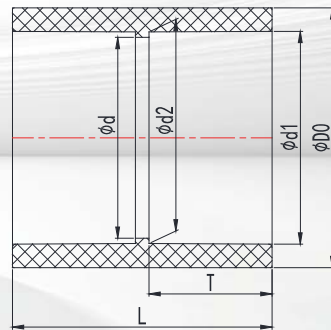
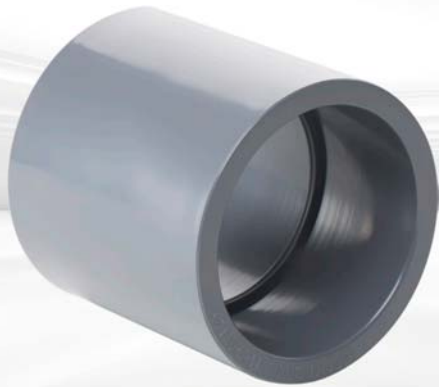

产品参数 (国标 DIN)

尺寸 Size DN	外形尺寸 Dimensions (mm)						公称压力 Nominal Pressure PN(kg/cm ²)
	D0	d1	d2	d	T	L	
15	26.30	20.30	19.95	18.00	16.20	34.40	S5(PN20)
20	31.80	25.30	24.95	23.00	18.70	39.00	S5(PN20)
25	39.90	32.30	31.90	30.00	22.20	46.40	S5(PN20)
32	49.40	40.40	39.90	38.00	26.20	54.40	S5(PN20)
40	61.40	50.40	49.90	48.00	31.20	64.40	S5(PN20)
50	77.10	63.40	62.90	61.00	37.70	77.10	S5(PN20)
65	91.00	75.40	74.90	68.20	43.70	90.00	S6.3(PN16)
80	107.60	90.50	89.90	83.80	51.20	106.40	S6.3(PN16)
100	127.20	110.60	109.90	103.00	61.20	128.30	S6.3(PN16)
De125	144.30	125.70	124.90	118.60	68.70	144.00	S6.3(PN16)
125	161.60	140.80	139.90	133.80	76.20	159.50	S6.3(PN16)
150	184.60	160.80	159.90	153.80	86.20	179.70	S6.3(PN16)
De180	202.60	180.90	179.90	178.50	97.00	199.00	S6.3(PN16)
De200	230.30	201.00	199.90	193.50	106.20	217.50	S6.3(PN16)
200	259.40	226.20	224.90	216.90	119.10	243.00	S6.3(PN16)
De250	287.90	251.30	249.90	241.90	131.65	268.30	S8(PN16)
250	314.50	281.50	279.90	278.00	147.00	300.00	S8(PN16)
300	354.00	316.70	314.90	306.90	164.30	335.40	S8(PN16)
350	384.25	356.80	355.00	326.00	184.30	373.50	PN6
400	430.15	402.00	400.00	369.80	205.50	422.80	PN6

产品参数 (美标 ASTM SCH80)

尺寸 Size (*")	外形尺寸 Dimensions (mm)					
	D0	d1	d2	d	T	L
1/2"	30.50	21.54	21.23	17.00	23.22	50.40
3/4"	36.90	26.87	26.57	22.50	26.40	56.80
1"	44.70	33.66	33.27	29.00	29.57	63.10
1-1/4"	54.00	42.42	42.04	38.00	32.75	69.50
1-1/2"	60.60	48.56	48.11	43.00	35.93	75.80
2"	73.10	60.63	60.17	55.00	39.10	82.20
2-1/2"	88.40	73.38	72.85	67.50	45.45	96.00
3"	105.30	89.31	88.70	83.00	48.63	102.30
4"	132.00	114.76	114.07	106.00	58.15	124.00
5"	161.90	141.81	141.04	133.00	67.68	144.00
6"	190.90	168.83	168.00	160.00	77.20	164.40
8"	245.90	219.84	218.69	208.00	102.60	215.20
10"	305.80	273.81	272.67	262.50	128.00	266.00
12"	360.60	324.60	323.47	313.00	153.40	316.80
14"	394.11	355.94	354.33	331.50	200.00	378.00
16"	450.00	407.19	405.33	363.80	230.66	420.00

PVC-U/C FEMALE ADAPTOR

内丝, PVC-U/C (国标, 美标)

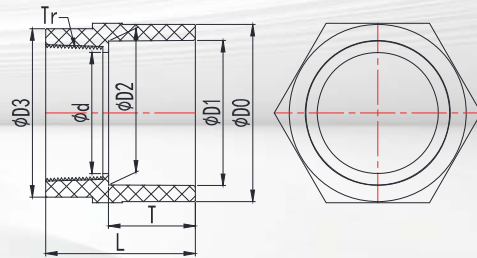

产品参数 (国标 DIN)

尺寸 Size DN	外形尺寸 Dimensions (mm)								公称压力 Nominal Pressure PN(kg/cm ²)
	D0	D1	D2	D3	d	T	L	Tr 螺纹	
15	27.10	20.30	19.95	27.60	16.50	16.50	33.50	1/2"	S5(PN20)
20	32.50	25.30	24.95	33.60	22.00	19.00	37.00	3/4"	S5(PN20)
25	40.30	32.30	31.90	41.30	28.00	22.50	42.20	1"	S5(PN20)
32	49.50	40.35	39.90	51.10	36.00	26.50	49.00	1-1/4"	S5(PN20)
40	61.60	50.35	49.90	59.00	42.00	31.50	54.00	1-1/2"	S5(PN20)
50	77.40	63.40	62.90	73.60	53.00	38.00	65.50	2"	S5(PN20)
65	90.40	75.40	74.90	90.20	68.00	44.00	76.00	2-1/2"	S6.3(PN16)
80	106.50	90.50	89.90	107.60	80.00	51.50	86.50	3"	S6.3(PN16)
100	126.90	110.60	109.90	129.40	104.50	61.50	103.00	4"	S6.3(PN16)

产品参数 (美标 ASTM SCH80)

尺寸 Size (*")	外形尺寸 Dimensions (mm)							
	D0	D1	D2	D3	d	T	L	Tr 螺纹 NTP
1/2"	29.70	21.54	21.23	29.22	16.00	23.22	40.22	1/2"
3/4"	35.30	26.87	26.57	34.97	20.60	26.40	44.40	3/4"
1"	43.70	33.66	33.27	43.35	26.00	29.57	49.60	1"
1-1/4"	53.10	42.42	42.04	52.58	36.00	32.75	55.25	1-1/4"
1-1/2"	59.90	48.56	48.11	59.45	41.00	35.93	58.45	1-1/2"
2"	73.10	60.63	60.17	72.10	52.00	39.10	66.60	2"
2-1/2"	88.00	73.38	72.85	87.30	64.00	45.45	77.50	2-1/2"
3"	105.30	89.31	88.70	104.60	78.00	48.63	83.65	3"
4"	132.00	114.76	114.07	131.65	102.50	58.15	99.70	4"

EXPERT IN PIPING SYSTEM

管路系统的专家级工厂



PVC-U/C MALE ADAPTOR

外丝, PVC-U/C (国标, 美标)

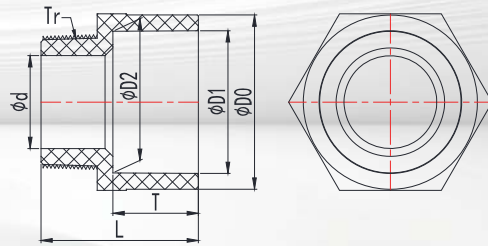

产品参数 (国标 DIN)

尺寸 Size DN	外形尺寸 Dimensions (mm)							公称压力 Nominal Pressure PN(kg/cm ²)
	D0	D1	D2	d	T	L	Tr 螺纹	
15	26.80	20.30	19.95	11.30	16.50	35.00	1/2"	S5(PN20)
20	32.50	25.30	24.95	16.10	19.00	38.50	3/4"	S5(PN20)
25	40.30	32.30	31.90	21.40	22.50	44.50	1"	S5(PN20)
32	49.50	40.35	39.90	28.80	26.50	51.00	1-1/4"	S5(PN20)
40	61.60	50.35	49.90	32.50	31.50	56.50	1-1/2"	S5(PN20)
50	77.00	63.40	62.90	41.30	38.00	69.40	2"	S5(PN20)
65	90.40	75.40	74.90	55.80	44.00	79.90	2-1/2"	S6.3(PN16)
80	106.50	90.50	89.90	67.30	51.50	91.50	3"	S6.3(PN16)
100	126.90	110.60	109.90	91.60	61.50	108.00	4"	S6.3(PN16)

产品参数 (美标 ASTM SCH80)

尺寸 Size (*")	外形尺寸 Dimensions (mm)						
	D0	D1	D2	d	T	L	Tr 螺纹
1/2"	29.55	21.54	21.23	11.30	23.22	41.50	1/2"
3/4"	35.30	26.87	26.57	16.00	26.40	45.90	3/4"
1"	43.66	33.66	33.27	21.35	29.57	51.50	1"
1-1/4"	50.00	42.42	42.04	28.80	32.75	56.80	1-1/4"
1-1/2"	59.85	48.56	48.11	32.50	35.93	61.50	1-1/2"
2"	72.25	60.63	60.17	41.30	39.10	71.00	2"
2-1/2"	88.00	73.38	72.85	55.80	45.45	82.00	2-1/2"
3"	105.45	89.31	88.70	67.30	48.63	88.65	3"
4"	132.00	114.76	114.07	91.60	58.15	104.65	4"

EXPERT IN PIPING SYSTEM

管路系统的专家级工厂



PVC-U/C ONE-PIECE FLANGE

单片式法兰, PVC-U/C (国标, 美标)

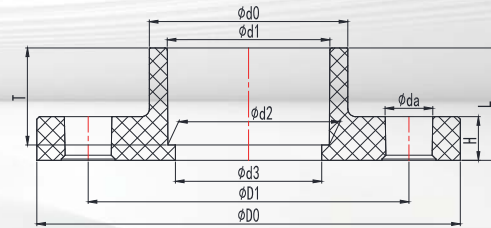

产品参数 (国标 DIN)

尺寸 Size DN	外形尺寸 Dimensions (mm)										公称压力 Nominal Pressure PN(kg/cm ²)	
	D0	D1	d0	d1	d2	d3	d _a	T	H	L		螺孔数 n
15	95.00	65.00	26.80	20.30	19.95	16.00	14.00	16.20	12.40	20.20	4	PN16
20	105.00	75.00	32.50	25.30	24.95	21.00	14.00	18.70	13.50	22.70	4	PN16
25	115.00	85.00	40.30	32.30	31.90	28.00	14.00	22.20	15.00	26.20	4	PN16
32	140.00	100.00	49.30	40.35	39.90	36.00	18.00	26.20	14.40	31.20	4	PN16
40	150.00	110.00	61.60	50.35	49.90	46.00	18.00	31.20	15.50	36.20	4	PN16
50	165.00	125.00	77.40	63.40	62.90	57.00	18.00	37.70	15.50	43.70	4	PN16
65	185.00	145.00	90.40	75.40	74.90	69.00	18.00	43.70	17.30	50.20	4	PN16
80	200.00	160.00	106.50	90.50	89.90	83.00	18.00	51.20	18.50	58.70	8	PN16
100	220.00	180.00	126.90	110.60	109.90	103.00	18.00	61.20	20.30	68.70	8	PN16
De125	250.00	210.00	144.00	125.70	124.90	117.00	18.00	68.70	22.00	77.20	8	PN16
125	250.00	210.00	161.30	140.75	139.90	131.50	18.00	76.20	22.20	84.70	8	PN16
150	285.00	240.00	184.30	160.80	159.90	151.00	22.00	86.20	25.00	95.70	8	PN16
De180	285.00	240.00	202.60	180.80	179.90	166.00	22.00	97.00	25.50	115.00	8	PN10
De200	340.00	295.00	227.00	201.00	199.90	190.00	22.00	106.20	26.30	116.20	8	PN10
200	340.00	295.00	254.10	226.20	224.90	216.00	22.00	119.10	27.00	129.70	8	PN10
De250	395.00	350.00	281.30	251.30	249.90	239.50	22.00	131.65	28.00	142.20	12	PN10
250	405.00	350.00	310.40	281.50	279.90	264.00	22.00	147.00	29.00	169.00	12	PN10
300	445.00	400.00	354.60	316.70	314.90	302.00	22.00	167.70	31.50	179.70	12	PN10

产品参数 (美标 ASTM SCH80)

尺寸 Size (*")	外形尺寸 Dimensions (mm)										螺孔数 n
	D0	D1	d0	d1	d2	d3	d _a	T	H	L	
1/2"	89.00	60.30	29.54	21.54	21.23	17.00	16.00	23.22	13.00	27.72	4
3/4"	89.00	69.85	35.27	26.87	26.57	22.50	16.00	26.40	14.00	30.90	4
1"	108.00	79.38	43.66	33.66	33.27	29.00	16.00	29.57	15.00	34.10	4
1-1/4"	117.00	88.90	53.02	42.42	42.04	38.00	16.00	32.75	15.00	38.75	4
1-1/2"	127.00	98.43	59.86	48.56	48.11	43.00	16.00	35.93	17.00	41.95	4
2"	152.00	120.65	72.23	60.63	60.17	55.00	19.00	39.10	19.00	46.10	4
2-1/2"	178.00	139.70	88.00	73.38	72.85	67.50	19.00	45.45	20.00	53.00	4
3"	191.00	152.40	105.30	89.31	88.70	83.00	19.00	48.63	20.50	57.15	4
4"	229.00	190.50	132.00	114.76	114.07	106.00	19.00	58.15	21.00	66.65	8
5"	254.00	216.00	162.00	141.81	141.04	133.00	22.00	67.68	23.50	77.50	8
6"	284.00	241.30	190.85	168.83	168.00	160.00	22.00	77.20	26.50	88.20	8
8"	343.00	298.45	245.84	219.84	218.69	208.00	22.00	102.60	27.00	113.60	8

PVC-U/C VANSTONE FLANGE

活套平承法兰, PVC-U/C (国标, 美标)

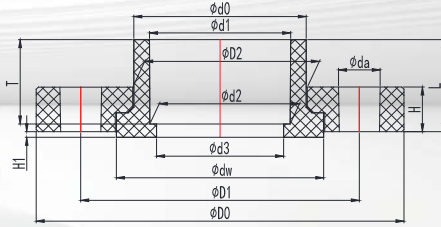

产品参数 (国标 DIN)

尺寸 Size DN	外形尺寸 Dimensions (mm)													公称压力 Nominal Pressure PN(kg/cm ²)	
	D0	D1	D2	d0	d1	d2	d3	d _w	d _a	T	H ₁	H	L		螺孔数 n
15	95.00	65.00	31.00	30.50	20.30	19.95	16.00	37.60	14.00	23.22	2.50	13.00	24.70	4	PN16
20	105.00	75.00	37.90	36.90	25.35	24.95	20.60	47.00	14.00	26.40	2.50	14.00	27.90	4	PN16
25	115.00	85.00	45.70	44.70	32.35	31.95	27.00	56.00	14.00	29.58	2.50	15.00	31.08	4	PN16
32	140.00	100.00	55.00	54.00	40.40	39.95	36.00	64.00	18.00	32.75	2.50	15.00	35.25	4	PN16
40	150.00	110.00	62.60	61.60	50.35	49.90	45.00	74.00	18.00	31.20	2.50	18.00	33.70	4	PN16
50	165.00	125.00	78.40	77.40	63.40	62.90	57.00	93.00	18.00	37.70	2.50	20.00	41.20	4	PN16
65	185.00	145.00	91.40	90.40	75.40	74.90	69.00	110.00	18.00	43.70	2.50	23.00	47.20	4	PN16
80	200.00	160.00	107.50	106.50	90.50	89.90	83.00	126.00	18.00	51.20	2.50	26.00	55.70	8	PN16
100	220.00	180.00	127.90	126.90	110.60	109.90	103.00	147.00	18.00	61.20	2.50	28.00	65.70	8	PN16
De125	250.00	210.00	145.00	144.00	125.70	124.90	117.00	164.00	18.00	68.70	2.50	29.00	74.20	8	PN16
125	250.00	210.00	162.30	161.30	140.75	139.90	131.50	181.00	18.00	76.20	2.50	30.00	81.70	8	PN16
150	285.00	240.00	186.30	184.30	160.80	159.90	151.00	204.00	22.00	86.20	3.00	32.00	92.20	8	PN16
De180	340.00	295.00	229.00	227.00	201.00	199.90	190.00	257.40	22.00	106.20	3.00	36.00	112.20	8	PN10
De200	340.00	295.00	256.10	254.10	226.20	224.90	216.00	271.00	22.00	119.10	3.00	38.00	127.70	8	PN10
200	395.00	350.00	283.30	281.30	251.30	249.90	239.50	310.00	22.00	131.65	3.50	40.00	138.20	12	PN10
De250	398.00	351.50	308.00	305.50	281.50	280.15	272.00	325.00	22.00	147.00	10.00	35.00	159.00	12	PN10
300	445.00	400.00	356.60	354.60	316.70	314.90	302.00	373.00	22.00	167.70	5.00	44.00	175.70	12	PN10
350	510.00	450.00	393.00	391.00	356.80	355.00	326.00	417.00	24.00	184.30	32.00	40.00	197.00	16	PN10
400	570.00	500.00	444.00	442.00	402.00	400.00	369.80	453.00	24.00	204.20	40.00	44.00	226.00	16	PN10
De450	620.00	565.00	488.50	486.00	451.94	450.05	447.00	518.00	27.00	233.00	38.00	45.00	245.00	20	PN10
De500	670.00	620.00	541.00	536.50	502.80	500.60	596.00	573.00	27.00	257.40	38.00	50.00	268.00	20	PN10

产品参数 (美标 ASTM SCH80)

尺寸 Size (")	外形尺寸 Dimensions (mm)													螺孔数 n
	D0	D1	D2	d0	d1	d2	d3	d _w	d _a	T	H ₁	H	L	
1/2"	89	61	31	30.5	21.54	21.23	16	37.6	16	23.22	2.5	13	24.72	4
3/4"	98	70	37.9	36.9	26.87	26.57	20.6	47	16	26.4	2.5	14	27.9	4
1"	108	79	45.7	44.7	33.66	33.27	27	56	16	29.58	2.5	15	31.08	4
1-1/4"	117	89	55	54	42.42	42.04	36	64	16	32.75	2.5	15	35.25	4
1-1/2"	127	98	62.6	61.6	50.46	50.46	45	72.4	16	35.93	2.5	18	38.43	4
2"	152	121	74.1	73.1	60.63	60.17	52.5	88.5	19	39.1	2.5	20	42.6	4
2-1/2"	178	140	89.4	88.4	73.38	72.85	65	108	19	45.5	2.5	23	49	4
3"	191	152	106.3	105.3	89.31	88.7	80	124.8	19	48.63	2.5	26	53.13	4
4"	229	191	133	132	114.76	114.07	102	152	19	58.15	2.5	28	62.65	8
5"	254	216	162.9	161.9	141.81	141.04	122	181.5	22	68	2.5	30	73.5	8
6"	284	241	192.5	191.5	168.83	168	150	209.5	22	77.2	3	32	83.2	8
8"	343	298	247.9	246.9	219.84	218.69	193	264.9	22	102.6	3	36	108.6	8
10"	410	362	309.8	305.8	273.81	272.67	262.5	327.37	24	128	3	42	138	12
12"	482.6	432	366.6	362.6	324.6	323.47	313	384.60	24	153.4	3	44	166	12
14"	534	476.3	402	399.2	356.6	355.5	331.5	426.6	28.6	183.5	3	52	186	12
16"	600	540.8	456	451.6	407.6	406.36	342.5	482.4	28.6	208	3	60	210	16

PVC-U/C BLIND FLANGE

盲法兰, PVC-U/C (国标, 美标)

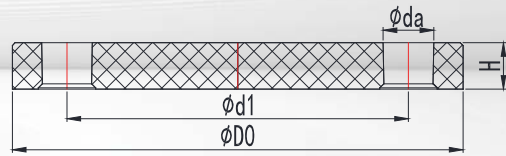

产品参数 (国标 DIN)

尺寸 Size DN	外形尺寸 Dimensions (mm)					公称压力 Nominal Pressure PN(kg/cm ²)
	D0	d1	da	H	螺孔数 n	
15	95.00	65.00	14.00	12.50	4	16
20	105.00	75.00	14.00	13.40	4	16
25	115.00	85.00	14.00	14.00	4	16
32	140.00	100.00	18.00	14.40	4	16
40	150.00	110.00	18.00	16.40	4	16
50	165.00	125.00	18.00	16.20	4	16
65	185.00	145.00	18.00	17.50	4	16
80	200.00	160.00	18.00	18.00	8	16
100	220.00	180.00	18.00	22.00	8	16
150	285.00	240.00	22.00	28.00	8	16
300	445.00	400.00	22.00	31.50	12	10
350	510.00	450.00	24.00	40.00	16	10
400	570.00	500.00	27.00	42.00	16	10

产品参数 (美标 ASTM SCH80)

尺寸 Size (英寸)	外形尺寸 Dimensions (mm)				
	D0	d1	da	H	螺孔数 n
1/2"	89.00	60.30	16.00	14.50	4
3/4"	89.00	69.85	16.00	15.30	4
1"	108.00	79.38	16.00	16.30	4
1-1/4"	117.00	88.90	16.00	15.80	4
1-1/2"	127.00	98.43	16.00	18.50	4
2"	152.00	120.65	19.00	20.50	4
2-1/2"	178.00	139.70	19.00	21.30	4
3"	191.00	152.40	19.00	22.00	4
4"	229.00	190.50	19.00	23.20	8
5"	254.00	216.00	22.00	25.00	8
6"	284.00	241.30	22.00	28.30	8
8"	343.00	298.45	22.00	28.70	8
10"	410.00	362.00	24.00	40.00	12
12"	482.60	432.00	24.00	42.00	12
14"	534.00	476.30	28.60	45.00	12
16"	598.35	540.80	28.60	52.00	16

PVC-U/C UNION

由任 (由令), PVC-U/C (国标, 美标)

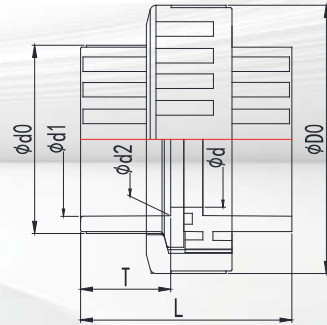

产品参数 (国标 DIN)

尺寸 Size DN	外形尺寸 Dimensions (mm)							公称压力 Nominal Pressure PN(kg/cm ²)
	D0	d0	d1	d2	d	T	L	
15	47.00	26.80	20.30	19.95	15.50	16.50	41.50	PN10
20	53.90	32.00	25.30	24.95	20.00	19.00	48.00	PN10
25	67.00	40.30	32.30	31.90	26.00	22.50	55.00	PN10
32	78.50	49.10	40.35	39.90	34.00	26.50	63.50	PN10
40	93.00	61.60	50.35	49.90	43.00	31.50	75.50	PN10
50	110.60	76.00	63.40	62.90	56.00	38.00	89.50	PN10
65	130.00	89.60	75.40	74.90	67.00	44.00	102.00	PN10
80	147.50	105.50	90.50	89.90	82.00	51.50	120.00	PN10
100	173.00	126.50	110.60	109.90	102.00	61.50	140.00	PN10

产品参数 (美标 ASTM SCH80)

尺寸 Size (*")	外形尺寸 Dimensions (mm)						
	D0	d0	d1	d2	d	T	L
1/2"	47.00	29.54	21.54	21.23	17.00	23.22	48.20
3/4"	54.00	35.36	26.87	26.57	22.50	26.40	55.50
1"	67.00	43.66	33.66	33.27	29.00	29.57	62.10
1-1/4"	78.50	53.02	42.42	42.04	38.00	32.75	70.00
1-1/2"	93.00	59.86	48.56	48.11	43.00	35.93	80.00
2"	110.60	72.23	60.63	60.17	55.00	39.10	90.50
2-1/2"	130.60	88.00	73.38	72.85	67.50	45.45	104.00
3"	148.50	105.30	89.31	88.70	83.00	48.63	117.00
4"	173.50	132.00	114.76	114.07	106.00	58.15	136.60

FLANGE GASKET

法兰垫片 (三元乙丙橡胶 EPDM, 氟橡胶 FPM) (国标, 美标)

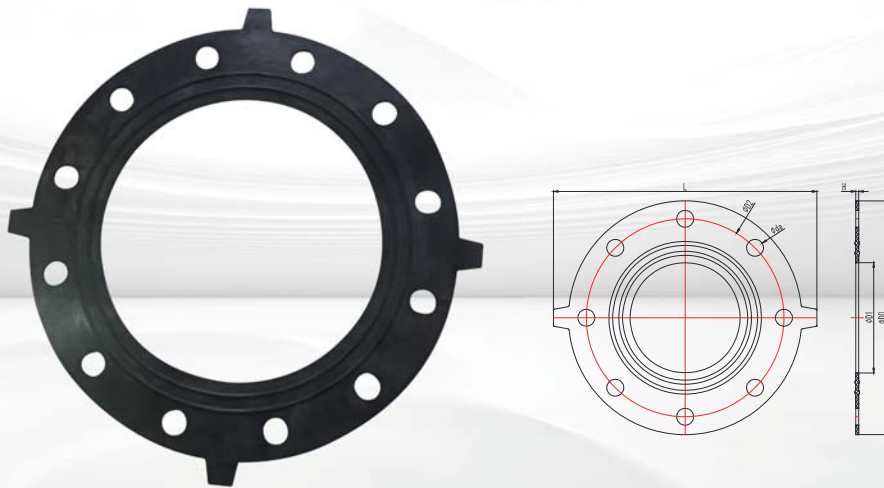

产品参数 (国标 DIN)

尺寸 Size DN	外形尺寸 Dimensions (mm)						
	D0	D1	D2	da	H	L	螺孔数 n
15	93.00	16.00	65.00	14.00	3.00	115.00	4
20	103.00	21.00	75.00	14.00	3.00	125.00	4
25	113.00	28.00	85.00	14.00	3.00	135.00	4
32	138.00	36.00	100.00	18.00	3.00	160.00	4
40	148.00	45.00	110.00	18.00	3.00	170.00	4
50	163.00	57.00	125.00	18.00	3.00	185.00	4
65	183.00	69.00	145.00	18.00	3.00	205.00	4
80	198.00	83.00	160.00	18.00	3.00	220.00	8
100	218.00	103.00	180.00	18.00	3.00	250.00	8
De125	248.00	117.00	210.00	18.00	3.00	280.00	8
125	248.00	131.50	210.00	18.00	3.00	280.00	8
150	283.00	151.00	240.00	22.00	3.00	315.00	8
De180	283.00	166.00	240.00	22.00	3.00	315.00	8
De200	338.00	190.00	295.00	22.00	3.00	370.00	8
200	338.00	203.00	295.00	22.00	3.00	370.00	8
De250	393.00	239.50	350.00	22.00	3.00	430.00	12
300	443.00	302.00	400.00	22.00	3.00	485.00	12
350	500.00	320.00	450.00	22.00	3.00	550.00	16
400	550.00	350.00	500.00	22.00	3.00	590.00	16

产品参数 (美标 ASTM SCH80)

尺寸 Size (英寸)	外形尺寸 Dimensions (mm)						
	D0	D1	D2	H	da	L	螺孔数 n
1/2"	87.00	16.00	60.33	16.00	3.00	109.00	4
3/4"	96.00	20.60	69.85	16.00	3.00	118.00	4
1"	106.00	27.00	79.38	16.00	3.00	128.00	4
1-1/4"	115.00	36.00	88.90	16.00	3.00	134.70	4
1-1/2"	125.00	41.50	98.43	16.00	3.00	146.60	4
2"	150.00	52.50	120.65	19.00	3.00	172.00	4
2-1/2"	176.00	65.00	139.70	19.00	3.00	198.00	4
3"	189.00	80.00	152.40	19.00	3.00	209.00	4
4"	226.00	102.00	190.50	19.00	3.00	258.00	8
5"	250.00	122.00	215.90	22.00	3.00	282.00	8
6"	281.00	150.00	241.30	22.00	3.00	313.00	8
8"	340.00	193.00	298.45	22.00	3.00	372.00	8
10"	408.00	262.50	362.00	25.00	3.00	450.00	12
12"	482.00	313.00	432.00	25.00	3.00	524.00	12
14"	543.00	342.50	476.30	28.60	3.00	573.00	12
16"	600.00	388.00	540.80	28.60	3.00	630.00	16

PVC-U BRACKET

管卡, PVC-U (国标)

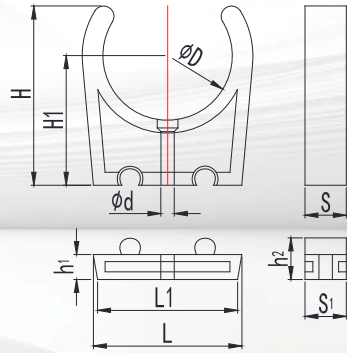

产品参数 (国标 DIN)

尺寸 Size DN	外形尺寸 Dimensions (mm)									
	D	H	H1	d	S	L	L1	h1	h2	S1
15	20.20	35.40	27.20	5.20	16.00	-	-	-	-	-
20	25.10	41.00	30.50	5.20	16.00	-	-	-	-	-
25	32.10	52.80	40.00	5.20	16.00	-	-	-	-	-
32	40.10	59.30	44.00	5.20	16.00	-	-	-	-	-
40	50.10	71.20	52.00	5.20	16.00	-	-	-	-	-
50	63.10	88.50	65.00	5.20	16.00	-	-	-	-	-
65	75.10	91.80	62.50	5.20	16.00	82.85	79.11	20.00	26.90	16.00
80	90.10	103.90	69.00	5.20	20.00	97.22	91.87	30.00	36.90	20.00
100	110.10	124.50	85.00	5.20	20.00	105	96.38	30.00	36.90	20.00
125	140.10	154.50	108.00	9.00	25.40					

EXPERT IN PIPING SYSTEM

管路系统的专家级工厂



PVC-U/C SOCKET TRUE UNION BALL VALVE

插口式双由令球阀, PVC-U/C (国标, 美标, 日标)

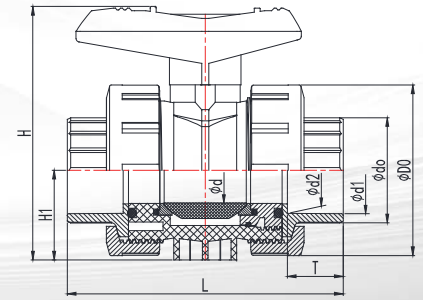

产品介绍

阀门描述

Valve description

1. 材质: PVC-U/C
Material: PVC-U/C
2. 尺寸: DN15-100 1/2" -4" 16A-100A
Size: DN15-100 1/2" -4" 16A-100A
3. 标准: 国标, 美标, 日标
Standard: DIN, ASTM, JIS
4. 连接: 插口
Connection: socket
5. 颜色: 把手红色, 本体: 深灰
Color: handle red, body: dark gray

产品特性

Product Features

1. 开关扭力小
Switch torque is small
2. 简单经济
Simple economy
3. 材料经过纳米改性, 提高产品的耐压性及抗冲击性
The material is nano-modified to improve the pressure resistance and impact resistance of the product
4. 阀体加厚处理, 抗压性能高
Thickened valve body for high compression resistance
5. 阀门出厂 100% 压力测试
Valve factory 100% pressure test

阀门 VALVE

产品参数 (国标 DIN)

尺寸 Size DN(De)	外形尺寸 Dimensions (mm)								
	D0	d0	d1	d2	d	T	H1	H	L
15(20)	51.50	27.40	20.30	19.95	15.50	17.00	26.30	82.80	95.50
20(25)	59.00	32.70	25.30	24.95	20.50	19.50	30.60	92.80	109.10
25(32)	70.00	41.30	32.30	31.90	26.00	23.00	39.10	109.20	122.60
32(40)	85.40	49.60	40.35	39.90	33.00	27.00	44.20	131.80	147.30
40(50)	98.90	60.20	50.35	49.90	39.00	32.00	52.20	143.20	158.80
50(63)	122.20	76.00	63.40	62.90	51.00	38.50	71.30	175.70	182.80
65(75)	158.60	89.60	75.40	74.90	64.00	44.50	82.80	231.50	234.00
80(90)	192.10	105.40	90.50	89.90	81.00	52.00	99.30	260.60	255.00
100(110)	223.60	128.40	110.60	109.90	99.00	62.00	115.20	292.10	297.00

产品参数 (美标 ASTM SCH80)

尺寸 Size (*")	外形尺寸 Dimensions (mm)								
	D0	d0	d1	d2	d	H1	H	T	L
1/2"	51.50	27.40	21.54	21.23	15.50	26.30	82.80	23.22	107.90
3/4"	59.00	32.70	26.87	26.57	20.50	30.60	92.80	26.40	122.90
1"	70.00	41.30	33.66	33.27	26.00	39.10	109.20	29.57	135.70
1-1/4"	85.40	49.60	42.42	42.04	33.00	44.20	131.80	32.75	158.80
1-1/2"	98.90	60.20	48.56	48.11	39.00	52.20	143.20	32.00	166.80
2"	122.20	76.00	60.63	60.17	51.00	71.30	175.70	39.10	182.80
2-1/2"	158.60	89.60	73.38	72.85	64.00	82.80	231.50	44.50	236.00
3"	192.10	105.40	89.31	88.70	81.00	99.30	260.60	48.60	249.00
4"	223.60	128.40	114.76	114.07	99.00	115.20	292.10	58.15	289.00

产品参数 (日标 JIS)

尺寸 Size A	外形尺寸 Dimensions (mm)								
	D0	d0	d1	d2	d	H1	H	T	L
16	51.50	30.50	22.40	21.60	15.50	26.30	82.80	30.00	121.80
20	59.00	34.11	26.45	25.51	20.50	30.60	92.80	35.00	140.60
25	70.00	41.30	32.66	31.50	26.00	39.10	109.20	40.00	157.10
30	85.40	48.16	38.60	37.43	33.00	44.20	131.80	44.00	184.00
40	98.90	59.10	48.85	47.38	39.00	52.20	143.20	55.00	207.20
50	122.20	72.10	61.00	59.27	51.00	71.30	175.70	63.00	235.00
65	158.60	89.23	77.10	75.73	64.00	82.80	231.50	63.00	273.00
75	192.10	105.33	89.60	88.58	81.00	99.30	260.60	64.00	279.00
100	223.60	133.07	114.70	113.55	99.00	115.20	292.10	84.00	342.60

序号 NO.	名称 Name	数量 Quantity	材料 Material
01	手柄 Lever	1	PVC-U/PP+GF30
02	连接杆 Shaft	1	PVC-U/C
03	螺帽 Nut	2	PVC-U/C
04	承口 Faucet	2	PVC-U/C
05	阀体 Body	1	PVC-U/C
06	球心 Ball	1	PVC-U/C
07	止泻圈 Ball Seat	2	PTFE
08	O型圈 1 O-ring1	2	EPDM/FPM
09	O型圈 2 O-ring2	2	EPDM/FPM
10	调节单盖 Seal Carrier	1	PVC-U/C
11	O型圈 3 O-ring3	1	EPDM/FPM
12	O型圈 4 O-ring4	2	EPDM/FPM

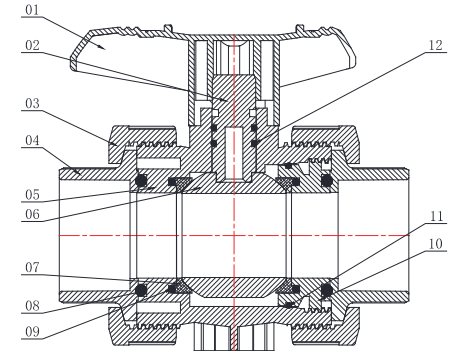

PVC-U/C THREADED TRUE UNION BALL VALVE

丝口式双由令球阀, PVC-U/C (国标, 美标, 日标)

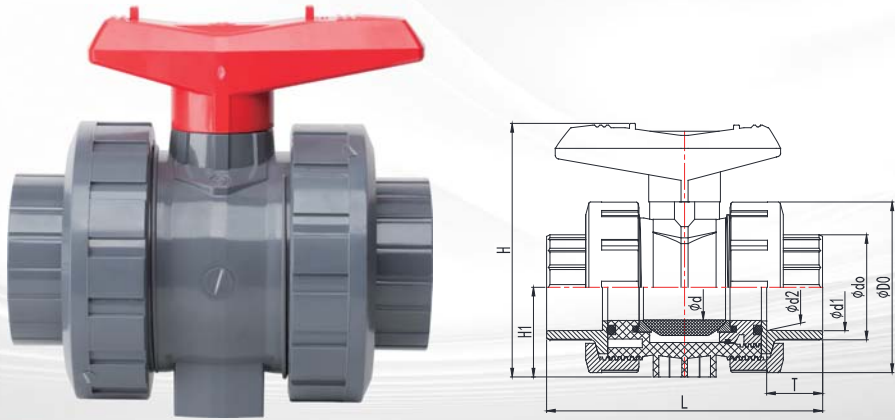

产品介绍

阀门描述 Valve description

1. 材质: PVC-U/C
Material: PVC-U/C
2. 尺寸: DN15-100 1/2" -4" 16A-100A
Size: DN15-100 1/2" -4" 16A-100A
3. 标准: 国标, 美标, 日标
Standard: DIN, ASTM, JIS
4. 连接: 丝口
Connection: Threaded
5. 颜色: 把手红色, 本体深灰
Color: handle red, body dark gray

产品特性 Product Features

1. 开关扭力小
Switch torque is small
2. 简单经济
Simple economy
3. 材料经过纳米改性, 提高产品的耐压性及抗冲击性
The material is nano-modified to improve the pressure resistance and impact resistance of the product
4. 阀体加厚处理, 抗压性能高
Thickened valve body for high compression resistance
5. 阀门出厂 100% 压力测试
Valve factory 100% pressure test

产品参数 (国标 DIN)

尺寸 Size DN(De)	外形尺寸 Dimensions (mm)										
	D0	d0	d1	d2	d3	d	H1	H	T	L	Tr 螺纹
15(20)	51.50	30.43	20.95	18.63	16.00	15.50	26.30	82.80	17.00	95.50	1/2"
20(25)	59.00	36.30	26.44	24.12	20.60	20.50	30.60	92.80	19.50	109.10	3/4"
25(32)	70.00	44.61	33.25	30.29	26.00	26.00	39.10	109.20	23.00	122.60	1"
32(40)	85.40	53.87	41.91	38.95	33.00	33.00	44.20	131.80	27.00	147.30	1-1/4"
40(50)	98.90	61.12	47.80	44.85	39.00	39.00	52.20	143.20	32.00	158.80	1-1/2"
50(63)	122.20	73.83	59.61	56.66	51.00	51.00	71.30	175.70	38.50	182.80	2"
65(75)	158.60	87.71	75.18	74.23	64.00	64.00	82.80	231.50	44.50	234.00	2-1/2"
80(90)	192.10	106.81	87.88	84.93	81.00	81.00	99.30	260.60	52.00	255.00	3"
100(110)	223.60	133.46	113.03	110.07	99.00	99.00	115.20	292.10	62.00	297.00	4"

产品参数 (美标 ASTM SCH80)

尺寸 Size (*")	外形尺寸 Dimensions (mm)										
	D0	d0	d1	d2	d3	d	H1	H	T	L	Tr 螺纹
1/2"	51.50	30.43	20.95	18.63	16.00	15.50	26.30	82.80	17.00	95.50	1/2"
3/4"	59.00	36.30	26.44	24.12	20.60	20.50	30.60	92.80	19.50	109.10	3/4"
1"	70.00	44.61	33.25	30.29	26.00	26.00	39.10	109.20	23.00	122.60	1"
1-1/4"	85.40	53.87	41.91	38.95	33.00	33.00	44.20	131.80	27.00	147.30	1-1/4"
1-1/2"	98.90	61.12	47.80	44.85	39.00	39.00	52.20	143.20	32.00	158.80	1-1/2"
2"	122.20	73.83	59.61	56.66	51.00	51.00	71.30	175.70	38.50	182.80	2"
2-1/2"	158.60	87.71	75.18	74.23	64.00	64.00	82.80	231.50	44.50	234.00	2-1/2"
3"	192.10	106.81	87.88	84.93	81.00	81.00	99.30	260.60	52.00	255.00	3"
4"	223.60	133.46	113.03	110.07	99.00	99.00	115.20	292.10	62.00	297.00	4"

产品参数 (日标 JIS)

尺寸 Size A	外形尺寸 Dimensions (mm)										
	D0	d0	d1	d2	d3	d	H1	H	T	L	Tr 螺纹
16	51.50	30.43	20.95	18.63	16.00	15.50	26.30	82.80	17.00	95.50	1/2"
20	59.00	36.30	26.44	24.12	20.60	20.50	30.60	92.80	19.50	109.10	3/4"
25	70.00	44.61	33.25	30.29	26.00	26.00	39.10	109.20	23.00	122.60	1"
30	85.40	53.87	41.91	38.95	33.00	33.00	44.20	131.80	27.00	147.30	1-1/4"
40	98.90	61.12	47.80	44.85	39.00	39.00	52.20	143.20	32.00	158.80	1-1/2"
50	122.20	73.83	59.61	56.66	51.00	51.00	71.30	175.70	38.50	182.80	2"
65	158.60	87.71	75.18	74.23	64.00	64.00	82.80	231.50	44.50	234.00	2-1/2"
75	192.10	106.81	87.88	84.93	81.00	81.00	99.30	260.60	52.00	255.00	3"
100	223.60	133.46	113.03	110.07	99.00	99.00	115.20	292.10	62.00	297.00	4"

序号 NO.	名称 Name	数量 Quantity	材料 Material
01	手柄 Lever	1	PVC-U/PP+GF30
02	连接杆 Shaft	1	PVC-U/C
03	螺帽 Nut	2	PVC-U/C
04	承口 Faucet	2	PVC-U/C
05	阀体 Body	1	PVC-U/C
06	球心 Ball	1	PVC-U/C
07	止泻圈 Ball Seat	2	PTFE
08	O 型圈 1 O-ring1	2	EPDM/FPM
09	O 型圈 2 O-ring2	2	EPDM/FPM
10	调节单盖 Seal Carrier	1	PVC-U/C
11	O 型圈 3 O-ring3	1	EPDM/FPM
12	O 型圈 4 O-ring4	2	EPDM/FPM

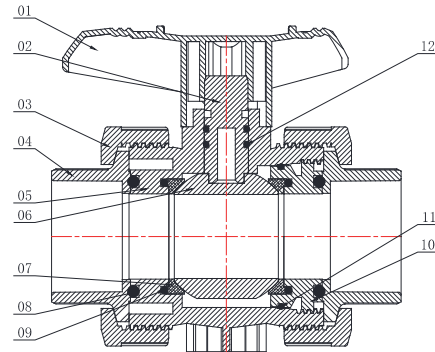

PVC-U/C FLANGED TRUE UNION BALL VALVE 法兰式双由令球阀, PVC-U/C (国标)

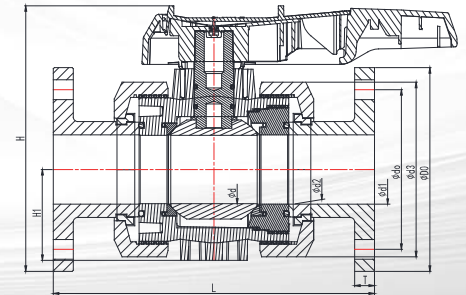

产品介绍

阀门描述 Valve description

1. 材质: PVC-U/C
Material: PVC-U/C
2. 尺寸: DN15-100
Size: DN15-100
3. 标准: 国标
Standard: DIN
4. 连接: 法兰
Connection: Flanged
5. 颜色: 把手红色, 本体: 深灰
Color: handle red, body: dark gray

产品特性 Product Features

1. 开关扭力小
Switch torque is small
2. 简单经济
Simple economy
3. 材料经过纳米改性, 提高产品的耐压性及抗冲击性
The material is nano-modified to improve the pressure resistance and impact resistance of the product
4. 阀体加厚处理, 抗压性能高
Thickened valve body for high compression resistance
5. 阀门出厂 100% 压力测试
Valve factory 100% pressure test

EXPERT IN PIPING SYSTEM

管路系统的专家级工厂



产品参数 (国标 DIN)

尺寸 Size DN(De)	外形尺寸 Dimensions (mm)									
	D0	d0	d1	d2	d3	d	H1	H	T	L
15(20)	95.00	65.00	20.30	19.95	51.50	15.50	26.30	103.90	13.00	143.00
20(25)	105.00	75.00	25.30	24.95	59.00	20.50	30.60	114.66	14.00	172.00
25(32)	115.00	85.00	32.30	31.90	70.00	26.00	39.10	127.56	15.00	187.00
32(40)	140.00	100.00	40.35	39.90	85.40	33.00	44.20	157.51	15.00	190.00
40(50)	150.00	110.00	50.35	49.90	98.90	39.00	52.20	166.00	17.00	212.00
50(63)	165.00	125.00	63.40	62.90	122.20	51.00	71.30	197.50	17.00	234.00
65(75)	185.00	145.00	75.40	74.90	158.60	64.00	82.80	241.20	18.00	290.00
80(90)	200.00	160.00	90.50	89.90	192.10	81.00	99.30	261.20	18.00	310.00
100(110)	220.00	180.00	110.60	109.90	223.60	99.00	115.20	286.68	18.00	372.00

序号 NO.	名称 Name	数量 Quantity	材料 Material
01	手柄 Lever	1	PVC-U/PP+GF30
02	连接杆 Shaft	1	PVC-U/C
03	螺母 Nut	2	PVC-U/C
04	法兰头 Flange	2	PVC-U/C
05	阀体 Body	1	PVC-U/C
06	球心 Ball	1	PVC-U/C
07	止泻圈 Ball Seat	2	PTFE
08	O型圈 1 O-ring1	2	EPDM/FPM
09	调节单盖 Seal Carrier	1	PVC-U/C
10	O型圈 2 O-ring2	2	EPDM/FPM
11	O型圈 3 O-ring3	1	EPDM/FPM
12	固定卡环 Fixed snap ring	2	PVC-U/C
13	O型圈 4 O-ring4	2	EPDM/FPM

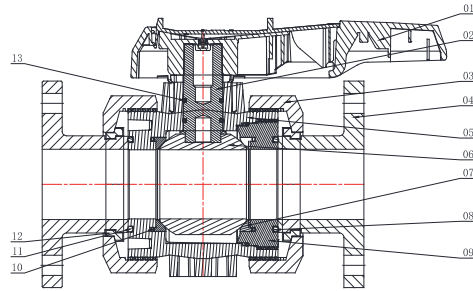
PVC-U/C
PNEUMATIC SOCKET TRUE UNION BALL VALVE

气动插口式双由令球阀, PVC-U/C (国标, 美标, 日标)

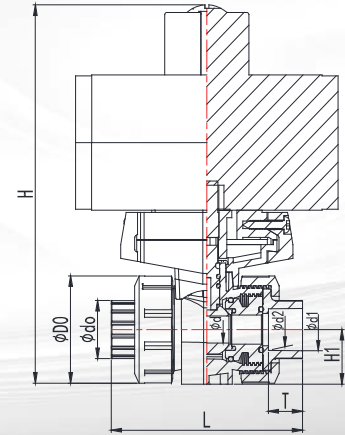

产品介绍

阀门描述
Valve description

1. 材质: PVC-U/C
Material: PVC-U/C
2. 尺寸: DN15-100 1/2" -4" 16A-100A
Size: DN15-100 1/2" -4" 16A-100A
3. 标准: 国标, 美标, 日标
Standard: DIN, ASTM, JIS
4. 连接: 插口
Connection: socket
5. 颜色: 本体: 灰
Color: body: gray

产品特性
Product Features

1. 开关扭力小
Switch torque is small
2. 部件可更换, 简单经济
Simple economy
3. 材料经过纳米改性, 提高产品的耐压性及抗冲击性
The material is nano-modified to improve the pressure resistance and impact resistance of the product
4. 阀体加厚处理, 抗压性能高
Thickened valve body for high compression resistance
5. 阀门出厂 100% 压力测试
Valve factory 100% pressure test
6. 执行器进行 50 万次开启关闭试验
Actuator performs 500,000 opening and closing tests
7. 可以选配单作用执行器及各种电磁阀, 回讯位置开关
Optional single-acting actuator and various solenoid valves, return position switch

产品参数 (国标 DIN)

尺寸 Size DN(De)	外形尺寸 Dimensions (mm)								
	D0	d0	d1	d2	d	H1	H	T	L
15(20)	51.50	27.40	20.30	19.95	15.50	26.30	156.50	17.00	95.50
20(25)	59.00	32.70	25.30	24.95	20.50	30.60	194.00	19.50	109.10
25(32)	70.00	41.30	32.30	31.90	26.00	39.10	210.00	23.00	122.60
32(40)	85.40	49.60	40.35	39.90	33.00	44.20	243.40	27.00	147.30
40(50)	98.90	60.20	50.35	49.90	39.00	52.20	268.90	32.00	158.80
50(63)	122.20	76.00	63.40	62.90	51.00	71.30	301.20	38.50	182.80
65(75)	158.60	89.60	75.40	74.90	64.00	82.80	373.60	44.50	234.00
80(90)	192.10	105.40	90.50	89.90	81.00	99.30	430.10	52.00	255.00
100(110)	223.60	128.40	110.60	109.90	99.00	115.20	493.60	62.00	297.00

产品参数 (美标 ASTM SCH80)

尺寸 Size (*")	外形尺寸 Dimensions (mm)								
	D	d0	d1	d2	d	H1	H	T	L
1/2"	51.50	27.40	21.54	21.23	15.50	26.30	156.50	23.22	107.90
3/4"	59.00	32.70	26.87	26.57	20.50	30.60	194.00	26.40	122.90
1"	70.00	41.30	33.66	33.27	26.00	39.10	210.00	29.57	135.70
1-1/4"	85.40	49.60	42.42	42.04	33.00	44.20	243.40	32.75	158.80
1-1/2"	98.90	60.20	48.56	48.11	39.00	52.20	268.90	32.00	166.80
2"	122.20	76.00	60.63	60.17	51.00	71.30	301.20	39.10	182.80
2-1/2"	158.60	89.60	73.38	72.85	64.00	82.80	373.60	44.50	236.00
3"	192.10	105.40	89.31	88.70	81.00	99.30	430.10	48.60	249.00
4"	223.60	128.40	114.76	114.07	99.00	115.20	493.60	58.15	289.00

产品参数 (日标 JIS)

尺寸 Size A	外形尺寸 Dimensions (mm)								
	D0	d0	d1	d2	d	H1	H	T	L
16	51.50	30.50	22.40	21.60	15.50	26.30	156.50	30.00	121.80
20	59.00	34.11	26.45	25.51	20.50	30.60	194.00	35.00	140.60
25	70.00	41.30	32.66	31.50	26.00	39.10	210.00	40.00	157.10
30	85.40	48.16	38.60	37.43	33.00	44.20	243.40	44.00	184.00
40	98.90	59.10	48.85	47.38	39.00	52.20	268.90	55.00	207.20
50	122.20	72.10	61.00	59.27	51.00	71.30	301.20	63.00	235.00
65	158.60	89.23	77.10	75.73	64.00	82.80	373.60	63.00	273.00
75	192.10	105.33	89.60	88.58	81.00	99.30	430.10	64.00	279.00
100	223.60	133.07	114.70	113.55	99.00	115.20	493.60	84.00	342.60

序号 NO.	名称 Name	数量 Quantity	材料 Material
01	气动执行器 Pneumatic Actuator	1	Aluminum alloy/plastic
02	连接件上盖 Connector top cover	1	PP+GF30
03	螺栓 Bolt	2	Stainless steel 304
04	连接件下盖 Connector bottom cover	1	PP+GF30
05	螺帽 Nut	2	PVC-U/C
06	承口 Faucet	2	PVC-U/C
07	调节单盖 Seal Carrier	1	PVC-U/C
08	止泻圈 Ball Seat	2	PTFE
09	O 型圈 1 O-ring1	2	EPDM/FPM
10	O 型圈 2 O-ring2	2	EPDM/FPM
11	O 型圈 3 O-ring3	1	EPDM/FPM
12	球心 Ball	1	PVC-U/C
13	O 型圈 4 O-ring4	2	EPDM/FPM
14	固定卡扣 Fixed buckle	2	PP+GF30
15	连接件 Connection	1	PP+GF30
16	螺栓 Bolt	4	Stainless steel 304
17	阀体 Body	1	PVC-U/C

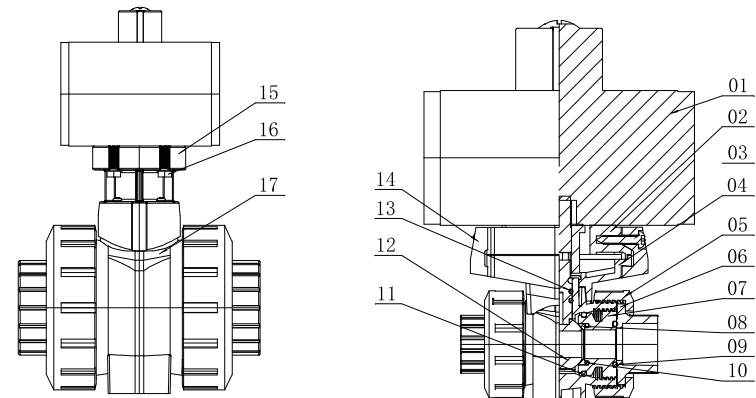
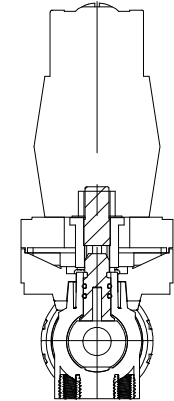

PVC-U/C PNEUMATIC FLANGED TRUE UNION BALL VALVE

气动法兰式双由令球阀, PVC-U/C (国标)

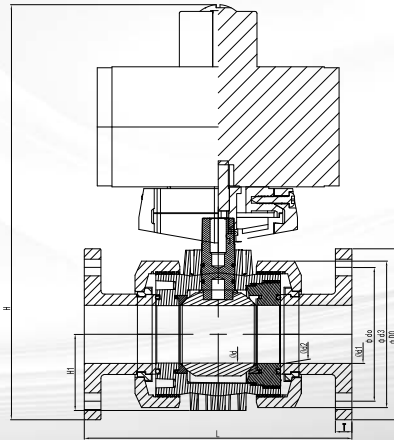

产品介绍

阀门描述 Valve description

1. 材质: PVC-U/C
Material: PVC-U/C
2. 尺寸: DN15-100
Size: DN15-100
3. 标准: 国标
Standard: DIN
4. 连接: 法兰
Connection: Flanged
5. 颜色: 本体: 灰
Color: body: gray

产品特性 Product Features

1. 开关扭力小
Switch torque is small
2. 部件可更换, 简单经济
Simple economy
3. 材料经过纳米改性, 提高产品的耐压性及抗冲击性
The material is nano-modified to improve the pressure resistance and impact resistance of the product
4. 阀体加厚处理, 抗压性能高
Thickened valve body for high compression resistance
5. 阀门出厂 100% 压力测试
Valve factory 100% pressure test
6. 执行器进行 50 万次开启关闭试验
Actuator performs 500,000 opening and closing tests
7. 可以选配单作用执行器及各种电磁阀, 回讯位置开关
Optional single-acting actuator and various solenoid valves, return position switch

产品参数 (国标 DIN)

尺寸 Size DN(De)	外形尺寸 Dimensions (mm)								
	D0	d0	d1	d2	d	H1	H	T	L
15(20)	95.00	65.00	20.30	19.95	15.50	26.30	178.25	13.00	143.00
20(25)	105.00	75.00	25.30	24.95	20.50	30.60	217.00	14.00	172.00
25(32)	115.00	85.00	32.30	31.90	26.00	39.10	232.50	15.00	187.00
32(40)	140.00	100.00	40.35	39.90	33.00	44.20	270.70	15.00	190.00
40(50)	150.00	110.00	50.35	49.90	39.00	52.20	294.45	17.00	212.00
50(63)	165.00	125.00	63.40	62.90	51.00	71.30	322.60	17.00	234.00
65(75)	185.00	145.00	75.40	74.90	64.00	82.80	386.80	18.00	290.00
80(90)	200.00	160.00	90.50	89.90	81.00	99.30	434.05	18.00	310.00
100(110)	220.00	180.00	110.60	109.90	99.00	115.20	491.80	18.00	372.00

序号 NO.	名称 Name	数量 Quantity	材料 Material
01	气动执行器 Pneumatic Actuator	1	Aluminium alloy/Plastic
02	连接件上盖 Connector top cover	1	PP+GF30
03	螺栓 Bolt	2	Stainless steel 304
04	连接件下盖 Connector bottom cover	1	PP+GF30
05	螺母 Nut	2	PVC-U/C
06	法兰头 Flange	2	PVC-U/C
07	调节单盖 Seal Carrier	1	PVC-U/C
08	止泻圈 Ball Seat	2	PTFE
09	O 型圈 1 O-ring1	2	EPDM/FPM
10	O 型圈 2 O-ring2	2	EPDM/FPM
11	O 型圈 3 O-ring3	1	EPDM/FPM
12	球心 Ball	1	PVC-U/C
13	O 型圈 4 O-ring4	2	EPDM/FPM
14	固定卡扣 Fixed buckle	2	PP+GF30
15	连接件 Connection	1	PP+GF30
16	螺栓 Bolt	4	Stainless steel 304
17	阀体 Body	1	PVC-U/C
18	卡环 Snap ring	2	PVC-U/C

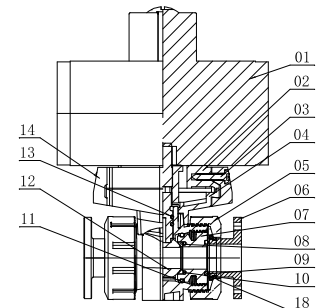
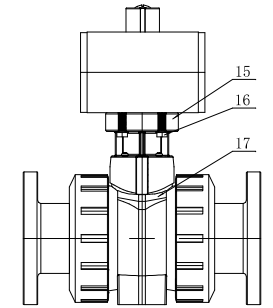

PVC-U/C PNEUMATIC THREADED TRUE UNION BALL VALVE

气动丝口式双由令球阀, PVC-U/C (国标, 美标, 日标)

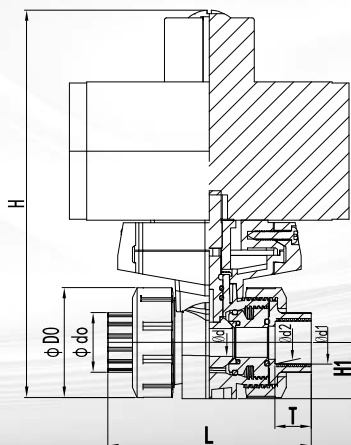

产品介绍

阀门描述 Valve description

1. 材质: PVC-U/C
Material: PVC-U/C
2. 尺寸: DN15-100 1/2" -4" 16A-100A
Size: DN15-100 1/2" -4" 16A-100A
3. 标准: 国标, 美标, 日标
Standard: DIN, ASTM, JIS
4. 连接: 丝口
Connection: Threaded
5. 颜色: 本体: 灰
Color: body: gray

产品特性 Product Features

1. 开关扭力小
Switch torque is small
2. 部件可更换, 简单经济
Simple economy
3. 材料经过纳米改性, 提高产品的耐压性及抗冲击性
The material is nano-modified to improve the pressure resistance and impact resistance of the product
4. 阀体加厚处理, 抗压性能高
Thickened valve body for high compression resistance
5. 阀门出厂 100% 压力测试
Valve factory 100% pressure test
6. 执行器进行 50 万次开启关闭试验
Actuator performs 500,000 opening and closing tests
7. 可以选配单作用执行器及各种电磁阀, 回讯位置开关
Optional single-acting actuator and various solenoid valves, return position switch

产品参数 (国标 DIN)

尺寸 Size DN(De)	外形尺寸 Dimensions (mm)								
	D0	d0	d1	d2	d	H1	H	T	L
15(20)	51.50	30.43	20.95	18.63	15.50	26.30	156.50	17.00	95.50
20(25)	59.00	36.30	26.44	24.12	20.50	30.60	194.00	19.50	109.10
25(32)	70.00	44.61	33.25	30.29	26.00	39.10	210.00	23.00	122.60
32(40)	85.40	53.87	41.91	38.95	33.00	44.20	243.40	27.00	147.30
40(50)	98.90	61.12	47.80	44.85	39.00	52.20	268.90	32.00	158.80
50(63)	122.20	73.83	59.61	56.66	51.00	71.30	301.20	38.50	182.80
65(75)	158.60	87.71	75.18	74.23	64.00	82.80	373.60	44.50	234.00
80(90)	192.10	106.81	87.88	84.93	81.00	99.30	430.10	52.00	255.00
100(110)	223.60	133.46	113.03	110.07	99.00	115.20	493.60	62.00	297.00

产品参数 (美标 ASTM SCH80)

尺寸 Size (*")	外形尺寸 Dimensions (mm)								
	D	d0	d1	d2	d	H1	H	T	L
1/2"	51.50	30.43	20.95	18.63	15.50	26.30	156.50	17.00	95.50
3/4"	59.00	36.30	26.44	24.12	20.50	30.60	194.00	19.50	109.10
1"	70.00	44.61	33.25	30.29	26.00	39.10	210.00	23.00	122.60
1-1/4"	85.40	53.87	41.91	38.95	33.00	44.20	243.40	27.00	147.30
1-1/2"	98.90	61.12	47.80	44.85	39.00	52.20	268.90	32.00	158.80
2"	122.20	73.83	59.61	56.66	51.00	71.30	301.20	38.50	182.80
2-1/2"	158.60	87.71	75.18	74.23	64.00	82.80	373.60	44.50	234.00
3"	192.10	106.81	87.88	84.93	81.00	99.30	430.10	52.00	255.00
4"	223.60	133.46	113.03	110.07	99.00	115.20	493.60	62.00	297.00

产品参数 (日标 JIS)

尺寸 Size A	外形尺寸 Dimensions (mm)								
	D0	d0	d1	d2	d	H1	H	T	L
16	51.50	30.43	20.95	18.63	15.50	26.30	156.50	17.00	95.50
20	59.00	36.30	26.44	24.12	20.50	30.60	194.00	19.50	109.10
25	70.00	44.61	33.25	30.29	26.00	39.10	210.00	23.00	122.60
30	85.40	53.87	41.91	38.95	33.00	44.20	243.40	27.00	147.30
40	98.90	61.12	47.80	44.85	39.00	52.20	268.90	32.00	158.80
50	122.20	73.83	59.61	56.66	51.00	71.30	301.20	38.50	182.80
65	158.60	87.71	75.18	74.23	64.00	82.80	373.60	44.50	234.00
75	192.10	106.81	87.88	84.93	81.00	99.30	430.10	52.00	255.00
100	223.60	133.46	113.03	110.07	99.00	115.20	493.60	62.00	297.00

序号 NO.	名称 Name	数量 Quantity	材料 Material
01	气动执行器 Pneumatic Actuator	1	Aluminum alloy/plastic
02	连接件上盖 Connector top cover	1	PP+GF30
03	螺栓 Bolt	2	304(不锈钢) Stainless steel 304
04	连接件下盖 Connector bottom cover	1	PP+GF30
05	螺帽 Nut	2	PVC-U/C
06	承口 Faucet	2	PVC-U/C
07	调节单盖 Seal Carrier	1	PVC-U/C
08	止泻圈 Ball Seat	2	PTFE
09	O 型圈 1 O-ring1	2	EPDM/FPM
10	O 型圈 2 O-ring2	2	EPDM/FPM
11	O 型圈 3 O-ring3	1	EPDM/FPM
12	球心 Ball	1	PVC-U/C
13	O 型圈 4 O-ring4	2	EPDM/FPM
14	固定卡扣 Fixed buckle	2	PP+GF30
15	连接件 Connection	1	PP+GF30
16	螺栓 Bolt	4	304(不锈钢) Stainless steel 304
17	阀体 Body	1	PVC-U/C

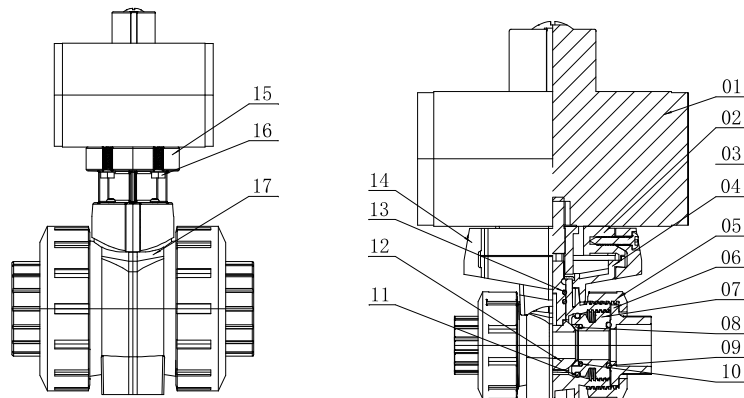
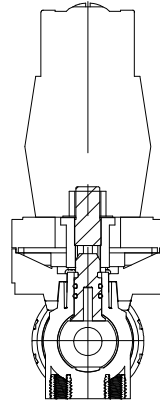

PVC-U/C ELECTRIC SOCKET TRUE UNION BALL VALVE

电动插口式双由令球阀, PVC-U/C (国标, 美标, 日标)

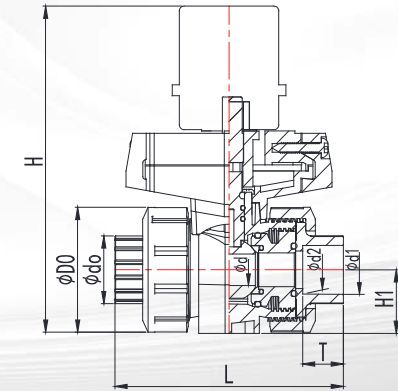

产品介绍

阀门描述

Valve description

1. 材质: PVC -U/C
Material: PVC -U/C
2. 尺寸: DN15-100 1/ 2" -4" 16A-100A
Size: DN15-100 1/ 2" -4" 16A-100A
3. 标准: 国标, 美标, 日标
Standard: DIN, ASTM, JIS
4. 连接: 插口
Connection: socket
5. 颜色: 本体: 灰
Color: body: gray

产品特性

Product Features

1. 开关扭力小
Switch torque is small
2. 部件可更换, 简单经济
Simple economy
3. 材料经过纳米改性, 提高产品的耐压性及抗冲击性
The material is nano-modified to improve the pressure resistance and impact resistance of the product
4. 阀体加厚处理, 抗压性能高
Thickened valve body for high compression resistance
5. 阀门出厂 100% 压力测试
Valve factory 100% pressure test
6. 可以选配调节型, 防爆及各种不同电压执行器
Optional adjustment, explosion-proof and various voltage actuators

产品参数 (国标 DIN)

尺寸 Size DN(De)	外形尺寸 Dimensions (mm)								
	D0	d0	d1	d2	d	H1	H	T	L
15(20)	51.50	27.40	20.30	19.95	15.50	26.30	201.50	17.00	95.50
20(25)	59.00	32.70	25.30	24.95	20.50	30.60	209.00	19.50	109.10
25(32)	70.00	41.30	32.30	31.90	26.00	39.10	220.00	23.00	122.60
32(40)	85.40	49.60	40.35	39.90	33.00	44.20	235.40	27.00	147.30
40(50)	98.90	60.20	50.35	49.90	39.00	52.20	248.90	32.00	158.80
50(63)	122.20	76.00	63.40	62.90	51.00	71.30	272.20	38.50	182.80
65(75)	158.60	89.60	75.40	74.90	64.00	82.80	353.60	44.50	234.00
80(90)	192.10	105.40	90.50	89.90	81.00	99.30	397.10	52.00	255.00
100(110)	223.60	128.40	110.60	109.90	99.00	115.20	438.60	62.00	297.00

产品参数 (美标 ASTM SCH80)

尺寸 Size (*")	外形尺寸 Dimensions (mm)								
	D0	d0	d1	d2	d	H1	H	T	L
1/2"	51.50	27.40	21.54	21.23	15.50	26.30	201.50	23.22	107.90
3/4"	59.00	32.70	26.87	26.57	20.50	30.60	209.00	26.40	122.90
1"	70.00	41.30	33.66	33.27	26.00	39.10	220.00	29.57	135.70
1-1/4"	85.40	49.60	42.42	42.04	33.00	44.20	235.40	32.75	158.80
1-1/2"	98.90	60.20	48.56	48.11	39.00	52.20	248.90	32.00	166.80
2"	122.20	76.00	60.63	60.17	51.00	71.30	272.20	39.10	182.80
2-1/2"	158.60	89.60	73.38	72.85	64.00	82.80	353.60	44.50	236.00
3"	192.10	105.40	89.31	88.70	81.00	99.30	397.10	48.60	249.00
4"	223.60	128.40	114.76	114.07	99.00	115.20	438.60	58.15	289.00

产品参数 (日标 JIS)

尺寸 Size A	外形尺寸 Dimensions (mm)								
	D0	d0	d1	d2	d	H1	H	T	L
16	51.50	30.50	22.40	21.60	15.50	26.30	201.50	30.00	121.80
20	59.00	34.11	26.45	25.51	20.50	30.60	209.00	35.00	140.60
25	70.00	41.30	32.66	31.50	26.00	39.10	220.00	40.00	157.10
30	85.40	48.16	38.60	37.43	33.00	44.20	235.40	44.00	184.00
40	98.90	59.10	48.85	47.38	39.00	52.20	248.90	55.00	207.20
50	122.20	72.10	61.00	59.27	51.00	71.30	272.20	63.00	235.00
65	158.60	89.23	77.10	75.73	64.00	82.80	353.60	63.00	273.00
75	192.10	105.33	89.60	88.58	81.00	99.30	397.10	64.00	279.00
100	223.60	133.07	114.70	113.55	99.00	115.20	438.60	84.00	342.60

序号 NO.	名称 Name	数量 Quantity	材料 Material
01	电动执行器 Electric Actuator	1	Aluminum alloy/plastic
02	连接件上盖 Connector top cover	1	PP+GF30
03	螺栓 Bolt	2	Stainless steel 304
04	连接件下盖 Connector bottom cover	1	PP+GF30
05	螺帽 Nut	2	PVC-U/C
06	承口 Faucet	2	PVC-U/C
07	调节单盖 Seal Carrier	1	PVC-U/C
08	止泻圈 Ball Seat	2	PTFE
09	O 型圈 1 O-ring1	2	EPDM/FPM
10	O 型圈 2 O-ring2	2	EPDM/FPM
11	O 型圈 3 O-ring3	1	EPDM/FPM
12	球心 Ball	1	PVC-U/C
13	O 型圈 4 O-ring4	2	EPDM/FPM
14	固定卡扣 Fixed buckle	2	PP+GF30
15	连接件 Connection	1	PP+GF30
16	螺栓 Bolt	4	Stainless steel 304
17	阀体 Body	1	PVC-U/C

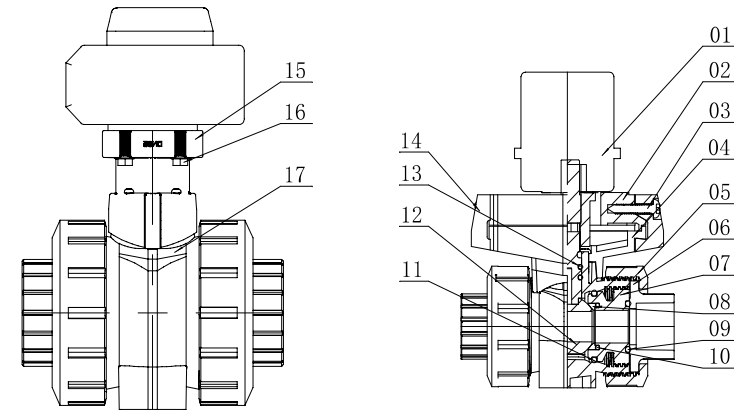

PVC-U/C ELECTRIC FLANGED TRUE UNION BALL VALVE

电动法兰式双由令球阀, PVC-U/C (国标)

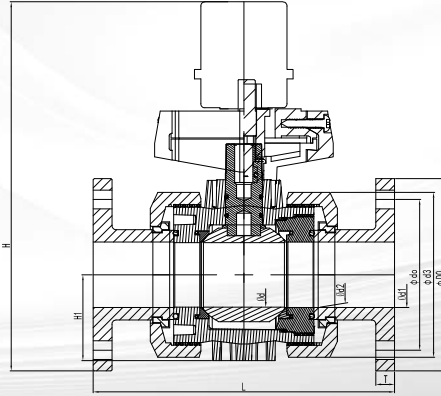

产品介绍

阀门描述 Valve description

1. 材质: PVC-U/C
Material: PVC-U/C
2. 尺寸: DN15-100
Size: DN15-100
3. 标准: 国标
Standard: DIN
4. 连接: 法兰
Connection: Flanged
5. 颜色: 本体: 灰
Color: body: gray

产品特性 Product Features

1. 开关扭力小
Switch torque is small
2. 部件可更换, 简单经济
Simple economy
3. 材料经过纳米改性, 提高产品的耐压性及抗冲击性
The material is nano-modified to improve the pressure resistance and impact resistance of the product
4. 阀体加厚处理, 抗压性能高
Thickened valve body for high compression resistance
5. 阀门出厂 100% 压力测试
Valve factory 100% pressure test
6. 可以选配调节型, 防爆及各种不同电压执行器
Optional adjustment, explosion-proof and various voltage actuators

产品参数 (国标 DIN)

尺寸 Size DN(De)	外形尺寸 Dimensions (mm)								
	D0	d0	d1	d2	d	H1	H	T	L
15(20)	95.00	65.00	20.30	19.95	15.50	26.30	223.25	13.00	143.00
20(25)	105.00	75.00	25.30	24.95	20.50	30.60	232.00	14.00	172.00
25(32)	115.00	85.00	32.30	31.90	26.00	39.10	242.50	15.00	187.00
32(40)	140.00	100.00	40.35	39.90	33.00	44.20	262.70	15.00	190.00
40(50)	150.00	110.00	50.35	49.90	39.00	52.20	274.45	17.00	212.00
50(63)	165.00	125.00	63.40	62.90	51.00	71.30	293.60	17.00	234.00
65(75)	185.00	145.00	75.40	74.90	64.00	82.80	366.80	18.00	290.00
80(90)	200.00	160.00	90.50	89.90	81.00	99.30	401.05	18.00	310.00
100(110)	220.00	180.00	110.60	109.90	99.00	115.20	436.80	18.00	372.00

序号 NO.	名称 Name	数量 Quantity	材料 Material
01	电动执行器 Electric Actuator	1	Aluminum alloy/plastic
02	连接件上盖 Connector top cover	1	PP+GF30
03	螺栓 Bolt	2	Stainless steel 304
04	连接件下盖 Connector bottom cover	1	PP+GF30
05	螺母 Nut	2	PVC-U/C
06	法兰头 Flange	2	PVC-U/C
07	调节单盖 Seal Carrier	1	PVC-U/C
08	止泻圈 Ball Seat	2	PTFE
09	O 型圈 1 O-ring1	2	EPDM/FPM
10	O 型圈 2 O-ring2	2	EPDM/FPM
11	O 型圈 3 O-ring3	1	EPDM/FPM
12	球心 Ball	1	PVC-U/C
13	O 型圈 4 O-ring4	2	EPDM/FPM
14	固定卡扣 Fixed buckle	2	PP+GF30
15	连接件 Connection	1	PP+GF30
16	螺栓 Bolt	4	Stainless steel 304
17	阀体 Body	1	PVC-U/C
18	卡环 Snap ring	2	PVC-U/C

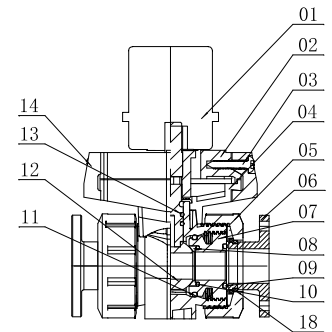
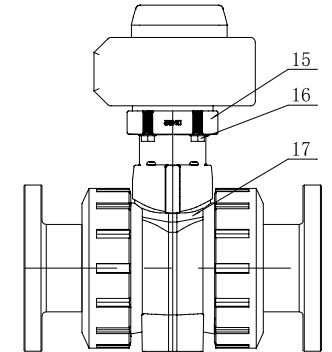

PVC-U/C ELECTRIC THREADED TRUE UNION BALL VALVE

电动丝口式双由令球阀, PVC-U/C (国标, 美标, 日标)

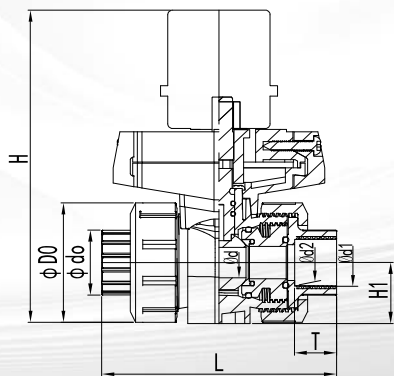

产品介绍

阀门描述 Valve description

1. 材质: PVC-U/C
Material: PVC-U/C
2. 尺寸: DN15-100 1/2" -4" 16A-100A
Size: DN15-100 1/2" -4" 16A-100A
3. 标准: 国标, 美标, 日标
Standard: DIN, ASTM, JIS
4. 连接: 丝口
Connection: Threaded
5. 颜色: 本体: 灰
Color: body: gray

产品特性 Product Features

1. 开关扭力小
Switch torque is small
2. 部件可更换, 简单经济
Simple economy
3. 材料经过纳米改性, 提高产品的耐压性及抗冲击性
The material is nano-modified to improve the pressure resistance and impact resistance of the product
4. 阀体加厚处理, 抗压性能高
Thickened valve body for high compression resistance
5. 阀门出厂 100% 压力测试
Valve factory 100% pressure test
6. 可以选配调节型, 防爆及各种不同电压执行器
Optional adjustment, explosion-proof and various voltage actuators

产品参数 (国标 DIN)

尺寸 Size DN(De)	外形尺寸 Dimensions (mm)								
	D0	d0	d1	d2	d	H1	H	T	L
15(20)	51.50	30.43	20.95	18.63	15.50	26.30	201.50	17.00	95.50
20(25)	59.00	36.30	26.44	24.12	20.50	30.60	209.00	19.50	109.10
25(32)	70.00	44.61	33.25	30.29	26.00	39.10	220.00	23.00	122.60
32(40)	85.40	53.87	41.91	38.95	33.00	44.20	235.40	27.00	147.30
40(50)	98.90	61.12	47.80	44.85	39.00	52.20	248.90	32.00	158.80
50(63)	122.20	73.83	59.61	56.66	51.00	71.30	272.20	38.50	182.80
65(75)	158.60	87.71	75.18	74.23	64.00	82.80	353.60	44.50	234.00
80(90)	192.10	106.81	87.88	84.93	81.00	99.30	397.10	52.00	255.00
100(110)	223.60	133.46	113.03	110.07	99.00	115.20	438.60	62.00	297.00

产品参数 (美标 ASTM SCH80)

尺寸 Size (*")	外形尺寸 Dimensions (mm)								
	D0	d0	d1	d2	d	H1	H	T	L
1/2"	51.50	30.43	20.95	18.63	15.50	26.30	201.50	17.00	95.50
3/4"	59.00	36.30	26.44	24.12	20.50	30.60	209.00	19.50	109.10
1"	70.00	44.61	33.25	30.29	26.00	39.10	220.00	23.00	122.60
1-1/4"	85.40	53.87	41.91	38.95	33.00	44.20	235.40	27.00	147.30
1-1/2"	98.90	61.12	47.80	44.85	39.00	52.20	248.90	32.00	158.80
2"	122.20	73.83	59.61	56.66	51.00	71.30	272.20	38.50	182.80
2-1/2"	158.60	87.71	75.18	74.23	64.00	82.80	353.60	44.50	234.00
3"	192.10	106.81	87.88	84.93	81.00	99.30	397.10	52.00	255.00
4"	223.60	133.46	113.03	110.07	99.00	115.20	438.60	62.00	297.00

产品参数 (日标 JIS)

尺寸 Size A	外形尺寸 Dimensions (mm)								
	D0	d0	d1	d2	d	H1	H	T	L
16	51.50	30.43	20.95	18.63	15.50	26.30	201.50	17.00	95.50
20	59.00	36.30	26.44	24.12	20.50	30.60	209.00	19.50	109.10
25	70.00	44.61	33.25	30.29	26.00	39.10	220.00	23.00	122.60
30	85.40	53.87	41.91	38.95	33.00	44.20	235.40	27.00	147.30
40	98.90	61.12	47.80	44.85	39.00	52.20	248.90	32.00	158.80
50	122.20	73.83	59.61	56.66	51.00	71.30	272.20	38.50	182.80
65	158.60	87.71	75.18	74.23	64.00	82.80	353.60	44.50	234.00
75	192.10	106.81	87.88	84.93	81.00	99.30	397.10	52.00	255.00
100	223.60	133.46	113.03	110.07	99.00	115.20	438.60	62.00	297.00

序号 NO.	名称 Name	数量 Quantity	材料 Material
01	电动执行器 Electric Actuator	1	Aluminum alloy/plastic
02	连接件上盖 Connector top cover	1	PP+GF30
03	螺栓 Bolt	2	Stainless steel 304
04	连接件下盖 Connector bottom cover	1	PP+GF30
05	螺帽 Nut	2	PVC-U/C
06	承口 Faucet	2	PVC-U/C
07	调节单盖 Seal Carrier	1	PVC-U/C
08	止泻圈 Ball Seat	2	PTFE
09	O型圈 1 O-ring1	2	EPDM/FPM
10	O型圈 2 O-ring2	2	EPDM/FPM
11	O型圈 3 O-ring3	1	EPDM/FPM
12	球心 Ball	1	PVC-U/C
13	O型圈 4 O-ring4	2	EPDM/FPM
14	固定卡扣 Fixed buckle	2	PP+GF30
15	连接件 Connection	1	PP+GF30
16	螺栓 Bolt	4	Stainless steel 304
17	阀体 Body	1	PVC-U/C

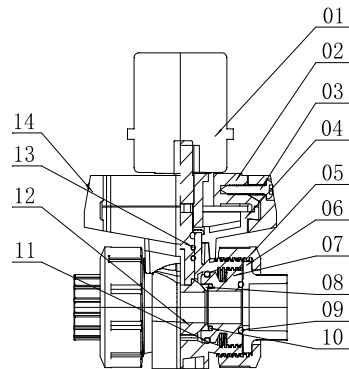
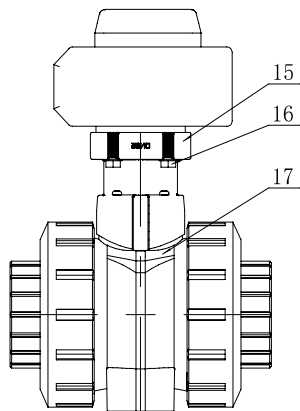

PVC-U/C HANDLED BUTTERFLY VALVE

手动式蝶阀, PVC-U/C (国标, 美标, 日标)

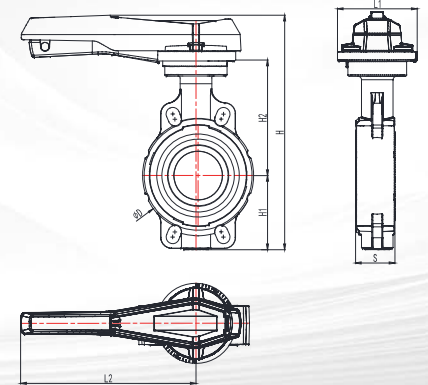

产品介绍

阀门描述

Valve description

1. 材质: PVC-U/C
Material: PVC-U/C
2. 尺寸: DN50-200 2"-8" 50A-200A
Size: DN50-200 2"-8" 50A-200A
3. 标准: 国标, 美标, 日标
Standard: DIN, ASTM, JIS
4. 连接: 法兰
Connection: Flanged
5. 颜色: 黑色, 把手红色, 阀板/阀座深灰
Colour: Black, Handle Red, Valve plate/seat dark gray

产品特性

Product Features

1. 双偏心结构设计, 使用寿命为普通蝶阀的 5 倍
Double eccentric structure design, the service life is 5 times that of ordinary butterfly valve
2. 开关扭力小
Switch torque is small
3. 部件可更换, 简单经济
Simple economy
4. 材料经过纳米改性, 提高产品的耐压性及抗冲击性
The material is nano-modified to improve the pressure resistance and impact resistance of the product
5. 阀体加厚处理, 抗压性能高
Thickened valve body for high compression resistance
6. 阀门出厂 100% 压力测试
Valve factory 100% pressure test
7. 本体和密封经过特殊处理, 性能更好
The body and seal are specially treated for better performance Actuator performs 500,000 opening and closing tests

产品参数 (国标 DIN)

尺寸 Size DN(De)	外形尺寸 Dimensions (mm)						
	D	H	H1	H2	S	L1	L2
50(63)	104.00	266.00	77.00	134.00	44.50	102.00	212.50
65(75)	114.30	275.00	83.00	140.00	46.00	102.00	212.50
80(90)	130.00	288.00	89.00	146.00	48.60	102.00	212.50
100(110)	160.40	332.00	104.00	167.00	55.50	115.00	253.30
125(140)	186.00	361.00	117.00	181.00	63.00	115.00	253.30
150(160)	215.00	379.00	130.00	189.00	72.00	115.00	253.30
200(225)	269.00	449.00	158.00	210.00	73.00	150.00	410.00

产品参数 (美标 ASTM SCH80)

尺寸 Size (*")	外形尺寸 Dimensions (mm)						
	D	H	H1	H2	S	L1	L2
2"	104.00	266.00	77.00	134.00	44.50	102.00	212.50
2-1/2"	114.30	275.00	83.00	140.00	46.00	102.00	212.50
3"	130.00	288.00	89.00	146.00	48.60	102.00	212.50
4"	160.40	332.00	104.00	167.00	55.50	115.00	253.30
5"	186.00	361.00	117.00	181.00	63.00	115.00	253.30
6"	215.00	379.00	130.00	189.00	72.00	115.00	253.30
8"	269.00	449.00	158.00	210.00	73.00	150.00	410.00

产品参数 (日标 JIS)

尺寸 Size A	外形尺寸 Dimensions (mm)						
	D	H	H1	H2	S	L1	L2
50	104.00	266.00	77.00	134.00	44.50	102.00	212.50
65	114.30	275.00	83.00	140.00	46.00	102.00	212.50
75	130.00	288.00	89.00	146.00	48.60	102.00	212.50
100	160.40	332.00	104.00	167.00	55.50	115.00	253.30
125	186.00	361.00	117.00	181.00	63.00	115.00	253.30
150	215.00	379.00	130.00	189.00	72.00	115.00	253.30
200	269.00	449.00	158.00	210.00	73.00	150.00	410.00

序号 NO.	名称 Name	数量 Quantity	材料 Material
01	手柄盖 Handle Cap	1	PP+GF30
02	手柄 Handle	1	PP+GF30
03	传动座 Drive Seat	1	PPS+GF40
04	齿轮座 Gear Seat	1	PP+GF30
05	挡圈 Collar	1	Stainless steel 304
06	定位套 Located Set	1	PP+GF30
07	阀体 Body	1	PP+GF30
08	导向套 Guide Sleeve	2	PVC-U/C
09	O 型圈 O-ring	8	EPDM/FPM
10	阀门套 Valve Sleeve	1	PVC-U/C
11	阀板 Disc	1	PVC-U/C
12	传动杆 Shaft	1	Stainless steel 316L
13	挡圈 Collar	1	Stainless steel 304
14	垫圈 Collar	1	Stainless steel 304
15	垫圈盖 Washer Cover	1	PP+GF30
16	制动把手 Brake Handle	1	PP+GF30
17	弹簧 Spring	1	Stainless steel 304
18	螺丝 Screw	1	Stainless steel 304
19	螺帽 Nut	1	Stainless steel 304
20	垫片 Gasket	1	Stainless steel 304
21	油封 SealRing	1	EPDM/FPM
22	胶圈 Rubber Ring	2	EPDM/FPM

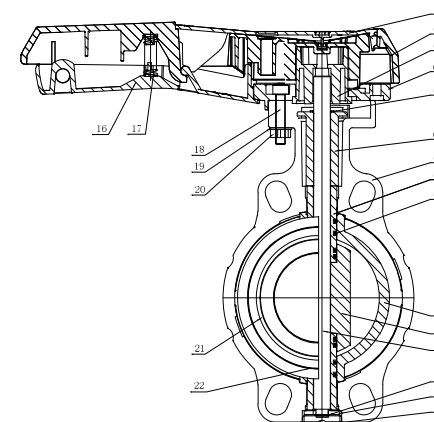

PVC-U/C GEARED BUTTERFLY VALVE

齿轮式蝶阀 (国标, 美标, 日标)

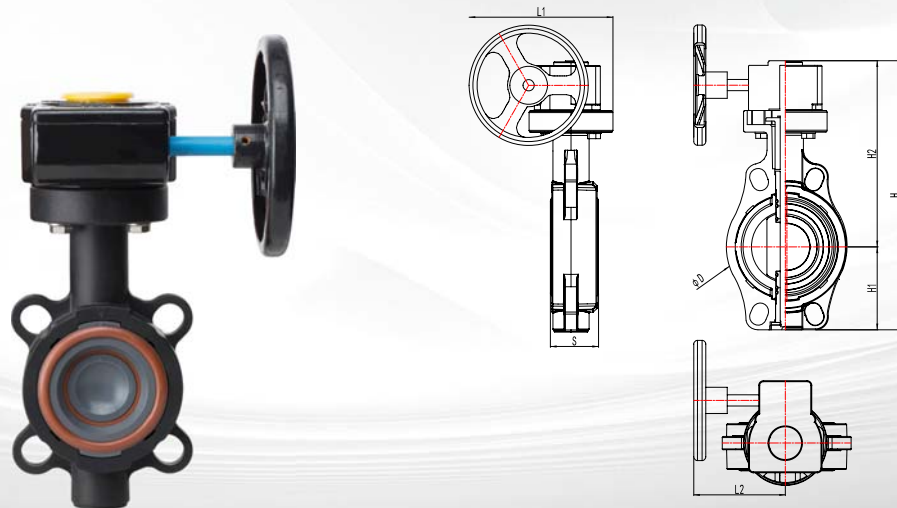

产品介绍

阀门描述 Valve description

1. 材质: PVC-U/C
Material: PVC-U/C
2. 尺寸: DN50-300 2"-12" 50A-318A
Size: DN50-300 2"-12" 50A-318A
3. 标准: 国标, 美标, 日标
Standard: DIN, ASTM, JIS
4. 连接: 法兰
Connection: Flanged
5. 颜色: 黑色, (阀板/阀座深灰)
Colour: Black, (Valve plate/seat dark gray)

产品特性 Product Features

1. 开关扭力小
Switch torque is small
2. 部件可更换, 简单经济
Simple economy
3. 材料经过纳米改性, 提高产品的耐压性及抗冲击性
The material is nano-modified to improve the pressure resistance and impact resistance of the product
4. 阀体加厚处理, 抗压性能高
Thickened valve body for high compression resistance
5. 阀门出厂 100% 压力测试
Valve factory 100% pressure test
6. 本体和密封经过特殊处理, 性能更好
The body and seal are specially treated for better performance. Actuator performs 500,000 opening and closing tests

产品参数 (国标 DIN)

尺寸 Size DN(De)	外形尺寸 Dimensions (mm)							公称压力 Nominal Pressure PN(kg/cm ²)
	D	H	H1	H2	S	L1	L2	
50(63)	104.00	307.48	77.00	230.48	44.50	153.00	108.00	10
65(75)	114.30	320.13	83.00	237.13	46.00	153.00	108.00	10
80(90)	130.00	332.13	89.00	243.13	48.60	153.00	108.00	10
100(110)	160.40	367.77	104.00	263.77	55.50	153.00	108.00	10
125(140)	186.00	411.47	117.00	294.47	63.00	166.00	119.00	10
150(160)	215.00	472.30	130.00	342.30	72.00	166.00	119.00	10
200(225)	269.00	521.54	158.00	363.54	73.00	268.00	223.00	6
250(280)	324.00	620.51	205.00	415.51	113.00	285.50	223.00	6
300(315)	336.60	722.24	228.00	494.24	114.40	342.50	323.00	6

产品参数 (美标 ASTM SCH80)

尺寸 Size (*")	外形尺寸 Dimensions (mm)							公称压力 Nominal Pressure PN(kg/cm ²)
	D	H	H1	H2	S	L1	L2	
2"	104.00	307.48	77.00	230.48	44.50	153.00	108.00	10
2-1/2"	114.30	320.13	83.00	237.13	46.00	153.00	108.00	10
3"	130.00	332.13	89.00	243.13	48.60	153.00	108.00	10
4"	160.40	367.77	104.00	263.77	55.50	153.00	108.00	10
5"	186.00	411.47	117.00	294.47	63.00	166.00	119.00	10
6"	215.00	472.30	130.00	342.30	72.00	166.00	119.00	10
8"	269.00	521.54	158.00	363.54	73.00	268.00	223.00	6
10"	324.00	620.51	205.00	415.51	113.00	285.50	223.00	6
12"	336.60	722.24	228.00	494.24	114.40	342.50	323.00	6

产品参数 (日标 JIS)

尺寸 Size A	外形尺寸 Dimensions (mm)							公称压力 Nominal Pressure PN(kg/cm ²)
	D	H	H1	H2	S	L1	L2	
50	104.00	307.48	77.00	230.48	44.50	153.00	108.00	10
65	114.30	320.13	83.00	237.13	46.00	153.00	108.00	10
75	130.00	332.13	89.00	243.13	48.60	153.00	108.00	10
100	160.40	367.77	104.00	263.77	55.50	153.00	108.00	10
125	186.00	411.47	117.00	294.47	63.00	166.00	119.00	10
150	215.00	472.30	130.00	342.30	72.00	166.00	119.00	10
200	269.00	521.54	158.00	363.54	73.00	268.00	223.00	6
267	324.00	620.51	205.00	415.51	113.00	285.50	223.00	6
318	336.60	722.24	228.00	494.24	114.40	342.50	323.00	6

序号 NO.	名称 Name	数量 Quantity	材料 Material
01	齿轮传动装置 Gear Drive Set	1	Aluminum alloy
02	挡圈 Collar	1	Stainless steel 304
03	定位套 Located Set	4	PP+GF30
04	垫片 Gasket	1	PP+GF30
05	螺栓 Bolt	4	Stainless steel 304
06	阀体 Body	1	PP+GF30
07	导向套 Guide Sleeve	2	PVC-U/C
08	O 型圈 O-ring	8	EPDM/FPM
09	阀门套 Valve Sleeve	1	PVC-U/C
10	阀板 Disc	1	PVC-U/C
11	油封 SealRing	1	EPDM/FPM
12	传动杆 Shaft	1	Stainless steel 316L
13	胶圈 Rubber Ring	1	EPDM/FPM
14	挡圈 Collar	1	Stainless steel 304
15	垫圈 Collar	1	Stainless steel 304
16	垫圈盖 Washer Cover	1	PP+GF30

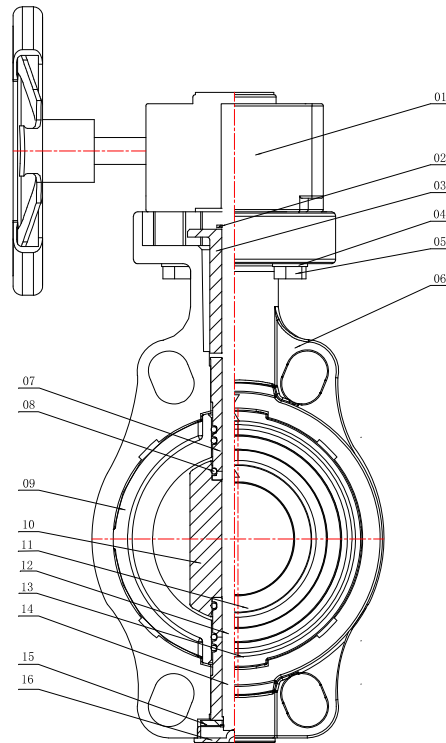

PVC-U/C PNEUMATIC BUTTERFLY VALVE

气动式蝶阀, PVC-U/C (国标, 美标, 日标)

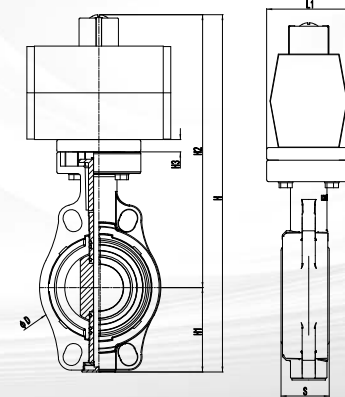

产品介绍

阀门描述

Valve description

1. 材质: PVC -U/C
Material: PVC -U/C
2. 尺寸: DN50-300 2"-12" 50A-318A
Size: DN50-300 2"-12" 50A-318A
3. 标准: 国标, 美标, 日标
Standard: DIN, ASTM, JIS
4. 连接: 法兰
Connection: Flanged
5. 颜色: 黑色, (阀板 / 阀座深灰)
Colour: Black, (Valve plate/seat dark gray)

产品特性

Product Features

1. 开关扭力小
Switch torque is small
2. 部件可更换, 简单经济
Simple economy
3. 材料经过纳米改性, 提高产品的耐压性及抗冲击性
The material is nano-modified to improve the pressure resistance and impact resistance of the product
4. 阀体加厚处理, 抗压性能高
Thickened valve body for high compression resistance
5. 可选配电磁阀, 位置开关等气缸配件
Valve factory 100% pressure test
6. 执行器进行 50 万次开启关闭试验
Actuator performs 500,000 opening and closing tests
7. 可以选配单作用执行器及各种电磁阀, 回讯位置开关
Optional single-acting actuator and various solenoid valves, return position switch

产品参数 (国标 DIN)

尺寸 Size DN(De)	外形尺寸 Dimensions (mm)						
	D	H	H1	H2	H3	S	L1
50(63)	104.00	327.48	77.00	250.48	15.00	44.50	90.00
65(75)	114.30	352.13	83.00	269.13	15.00	46.00	90.00
80(90)	130.00	384.13	89.00	295.13	15.00	48.60	90.00
100(110)	160.40	432.77	104.00	328.77	-	55.50	90.00
125(140)	186.00	481.47	117.00	364.47	-	63.00	90.00
150(160)	215.00	528.30	130.00	388.30	-	72.00	90.00
200(225)	269.00	593.54	158.00	435.54	-	73.00	90.00
250(280)	324.00	750.51	205.00	545.51	-	113.00	125.00
300(315)	336.60	888.24	228.00	660.24	-	114.40	125.00

产品参数 (美标 ASTM SCH80)

尺寸 Size (*")	外形尺寸 Dimensions (mm)						
	D	H	H1	H2	H3	S	L1
2"	104.00	327.48	77.00	250.48	15.00	44.50	90.00
2-1/2"	114.30	352.13	83.00	269.13	15.00	46.00	90.00
3"	130.00	384.13	89.00	295.13	15.00	48.60	90.00
4"	160.40	432.77	104.00	328.77	-	55.50	90.00
5"	186.00	481.47	117.00	364.47	-	63.00	90.00
6"	215.00	528.30	130.00	388.30	-	72.00	90.00
8"	269.00	593.54	158.00	435.54	-	73.00	90.00
10"	324.00	750.51	205.00	545.51	-	113.00	125.00
12"	336.60	888.24	228.00	660.24	-	114.40	125.00

产品参数 (日标 JIS)

尺寸 Size A	外形尺寸 Dimensions (mm)						
	D	H	H1	H2	H3	S	L1
50	104.00	327.48	77.00	250.48	15.00	44.50	90.00
65	114.30	352.13	83.00	269.13	15.00	46.00	90.00
75	130.00	384.13	89.00	295.13	15.00	48.60	90.00
100	160.40	432.77	104.00	328.77	-	55.50	90.00
125	186.00	481.47	117.00	364.47	-	63.00	90.00
150	215.00	528.30	130.00	388.30	-	72.00	90.00
200	269.00	593.54	158.00	435.54	-	73.00	90.00
267	324.00	750.51	205.00	545.51	-	113.00	125.00
318	336.60	888.24	228.00	660.24	-	114.40	125.00

序号 NO.	名称 Name	数量 Quantity	材料 Material
01	气动执行器 Pneumatic Actuator	1	Aluminum Alloy
02	挡圈 Collar	1	Stainless steel 304
03	定位套 Located Set	4	PP+GF30
04	垫片 Gasket	1	PP+GF30
05	螺栓 Bolt	4	Stainless steel 304
06	阀体 Body	1	PP+GF30
07	导向套 Guide Sleeve	2	PVC-U/C
08	O 型圈 O-ring	8	EPDM/FPM
09	阀门套 Valve Sleeve	1	PVC-U/C
10	阀板 Disc	1	PVC-U/C
11	油封 SealRing	1	EPDM/FPM
12	传动杆 Shaft	1	Stainless steel 316L
13	胶圈 Rubber Ring	1	EPDM/FPM
14	挡圈 Collar	1	Stainless steel 304
15	垫圈 Collar	1	Stainless steel 304
16	垫圈盖 Washer Cover	1	PP+GF30

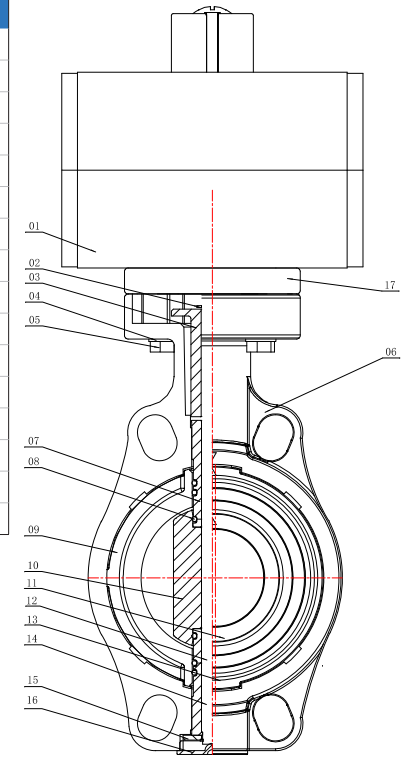

PVC-U/C ELECTRIC BUTTERFLY VALVE

电动式蝶阀, PVC-U/C (国标, 美标, 日标)

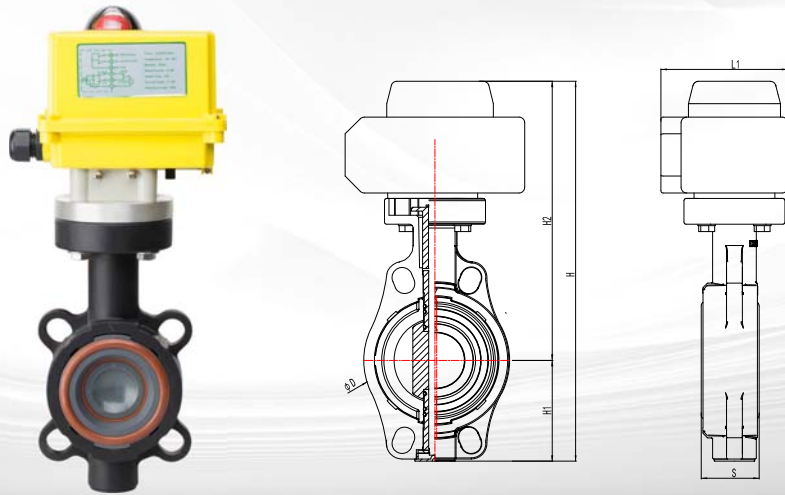

产品介绍

阀门描述 Valve description

1. 材质: PVC-U/C
Material: PVC-U/C
2. 尺寸: DN50-300 2"-12" 50A-318A
Size: DN50-300 2"-12" 50A-318A
3. 标准: 国标, 美标, 日标
Standard: DIN, ASTM, JIS
4. 连接: 法兰
Connection: Flanged
5. 颜色: 黑色 (执行器黄色, 阀板/阀座灰色)
Colour: Black, (Actuator yellow, Valve plate/seat dark gray)

产品特性 Product Features

1. 开关扭力小
Switch torque is small
2. 部件可更换, 简单经济
Simple economy
3. 材料经过纳米改性, 提高产品的耐压性及抗冲击性
The material is nano-modified to improve the pressure resistance and impact resistance of the product
4. 阀体加厚处理, 抗压性能高
Thickened valve body for high compression resistance
5. 阀门出厂 100% 压力测试
Valve factory 100% pressure test
6. 可以选配调节型, 防爆及各种不同电压执行器
Optional adjustment, explosion-proof and various voltage actuators

产品参数 (国标 DIN)

尺寸 Size DN(De)	外形尺寸 Dimensions (mm)					
	D	H	H1	H2	S	L1
50(63)	104.00	339.48	77.00	262.48	44.50	120.00
65(75)	114.30	352.13	83.00	269.13	46.00	120.00
80(90)	130.00	364.13	89.00	275.13	48.60	120.00
100(110)	160.40	429.77	104.00	325.77	55.50	130.00
125(140)	186.00	446.47	117.00	339.47	63.00	130.00
150(160)	215.00	477.30	130.00	347.30	72.00	130.00
200(225)	269.00	526.54	158.00	368.54	73.00	130.00
250(280)	324.00	660.51	205.00	455.51	113.00	170.00
300(315)	336.60	705.24	228.00	477.24	114.40	170.00

产品参数 (美标 ASTM SCH80)

尺寸 Size (")	外形尺寸 Dimensions (mm)					
	D	H	H1	H2	S	L1
2"	104.00	339.48	77.00	262.48	44.50	120.00
2-1/2"	114.30	352.13	83.00	269.13	46.00	120.00
3"	130.00	364.13	89.00	275.13	48.60	120.00
4"	160.40	429.77	104.00	325.77	55.50	130.00
5"	186.00	446.47	117.00	339.47	63.00	130.00
6"	215.00	477.30	130.00	347.30	72.00	130.00
8"	269.00	526.54	158.00	368.54	73.00	130.00
10"	324.00	660.51	205.00	455.51	113.00	170.00
12"	336.60	705.24	228.00	477.24	114.40	170.00

产品参数 (日标 JIS)

尺寸 Size A	外形尺寸 Dimensions (mm)					
	D	H	H1	H2	S	L1
50	104.00	339.48	77.00	262.48	44.50	120.00
65	114.30	352.13	83.00	269.13	46.00	120.00
75	130.00	364.13	89.00	275.13	48.60	120.00
100	160.40	429.77	104.00	325.77	55.50	130.00
125	186.00	446.47	117.00	339.47	63.00	130.00
150	215.00	477.30	130.00	347.30	72.00	130.00
200	269.00	526.54	158.00	368.54	73.00	130.00
267	324.00	660.51	205.00	455.51	113.00	170.00
318	336.60	705.24	228.00	477.24	114.40	170.00

序号 NO.	名称 Name	数量 Quantity	材料 Material
01	电动执行器 Electric Actuator	1	ABS/Aluminum Alloy
02	挡圈 Collar	1	Stainless steel 304
03	定位套 Located Set	4	PP+GF30
04	垫片 Gasket	1	PP+GF30
05	螺栓 Bolt	4	Stainless steel 304
06	阀体 Body	1	PP+GF30
07	导向套 Guide Sleeve	2	PVC-U/C
08	O 型圈 O-ring	8	EPDM/FPM
09	阀门套 Valve Sleeve	1	PVC-U/C
10	阀板 Disc	1	PVC-U/C
11	油封 SealRing	1	EPDM/FPM
12	传动杆 Shaft	1	Stainless steel 316L
13	胶圈 Rubber Ring	2	EPDM/FPM
14	挡圈 Collar	1	Stainless steel 304
15	垫圈 Collar	1	Stainless steel 304
16	垫圈盖 Washer Cover	1	PP+GF30

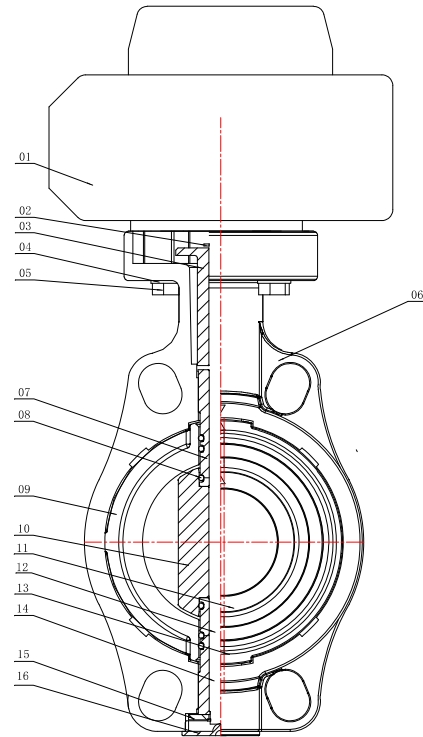

PVC-U/C FLANGED DIAPHRAGM VALVE 法兰式隔膜阀, PVC-U/C (国标)

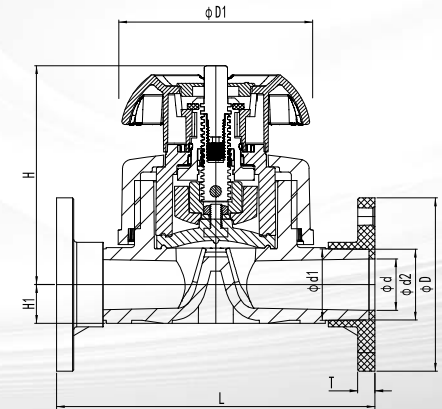

产品介绍

阀门描述

Valve description

1. 材质: PVC-U/C
Material: PVC-U/C
2. 尺寸: DN15-150
Size: DN15-150
3. 标准: 国标
Standard: DIN
4. 连接: 法兰式
Connection: Flanged
5. 颜色: 本体灰色, 阀盖黄色, 手柄黑色
Color: The body is gray, the bonnet is yellow, and the handle is black.

产品特性

Product Features

1. 开关扭力小
Switch torque is small
2. 部件可更换, 简单经济
Simple economy
3. 材料经过纳米改性, 提高产品的耐压性及抗冲击性
The material is nano-modified to improve the pressure resistance and impact resistance of the product
4. 阀体加厚处理, 抗压性能高
Thickened valve body for high compression resistance
5. 阀门出厂 100% 压力测试
Valve factory 100% pressure test
6. 本体和密封经过特殊处理, 性能更好
The body and seal are specially treated for better performance. Actuator performs 500,000 opening and closing tests

产品参数 (国标 DIN)

尺寸 Size DN(De)	外形尺寸 Dimensions (mm)									
	D	D1	d	H1	H	T	L	法兰中心距	法兰孔径	法兰孔径
15(20)	95.00	80.00	16.00	14.00	90.00	13.00	121.00	65.00	14.00	4
20(25)	105.00	80.00	21.00	18.00	102.00	14.00	142.00	75.00	14.00	4
25(32)	115.00	94.00	28.00	21.00	119.00	15.00	151.00	85.00	14.00	4
32(40)	140.00	117.00	36.00	26.00	126.00	15.00	169.00	100.00	16.00	4
40(50)	150.00	117.00	45.00	33.00	139.00	17.00	193.00	110.00	16.00	4
50(63)	165.00	152.00	57.00	39.00	172.00	17.00	227.00	125.00	19.00	4
65(75)	185.00	151.60	85.00	91.00	173.00	17.00	290.00	145.00	19.00	4
80(90)	197.00	263.00	85.00	109.00	226.00	18.00	310.00	160.00	19.00	8
100(110)	220.00	263.00	106.00	134.00	234.00	20.00	350.00	180.00	19.00	8
125(140)	250.00	263.00	106.00	134.00	234.00	22.00	350.00	210.00	22.00	8
150(160)	286.00	392.60	150.00	212.00	333.00	24.00	480.00	240.00	22.00	8

序号 NO.	名称 Name	数量 Quantity	材料 Material
01	阀体 (国标) Body(DIN)	1	PVC-U/C
02	隔膜片 Diaphragm	1	EPDM/FPM
03	隔膜片防水套 Diaphragm water seal sleeve	1	PP+GF30
04	六角螺栓 Hex bolt	1	Stainless steel 304
05	六角螺母 Hex nut	1	Stainless steel 304
06	阀瓣嵌件 Disc insert	1	Brass (H62)
07	指示杆 (内外嵌件) Indicator stem(both insert)	1	PP
08	盖板 Cover	1	PP
09	卡簧 Jump ring	1	Spring steel
10	手轮 Handwheel	1	PP+GF30/PA6+GF30
11	阀体螺帽 Body nut	1	PA6+GF30
12	阀杆 Stem	1	Stainless steel 304
13	销钉 pins	1	Stainless steel 304
14	阀杆螺母嵌件 Stem screw insert	1	Brass (H62)
15	阀杆螺母 Stem screw	1	PPS
16	阀瓣 Disc	1	PPS
17	一体法兰 One Piece Flange	2	PVC-U/C
18	透明罩 (DN65-DN150) Transparent cover	1	PC
19	手轮 (DN65-DN150) Handwheel	1	PA6+GF30
20	法兰式阀体 Flanged body	1	PVC-U/C

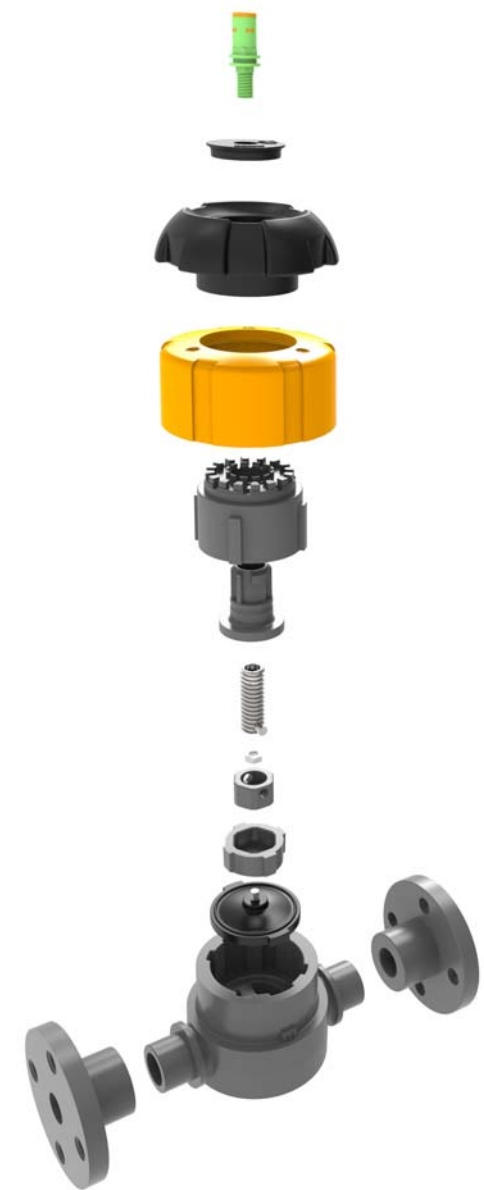
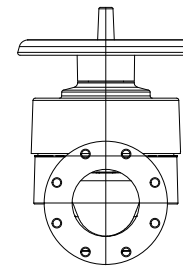
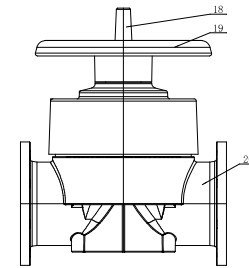
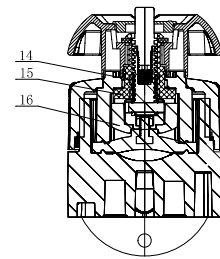
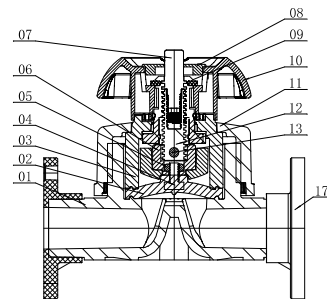

PVC-U/C SOCKET DIAPHRAGM VALVE

插口式隔膜阀, PVC-U/C (国标, 美标)

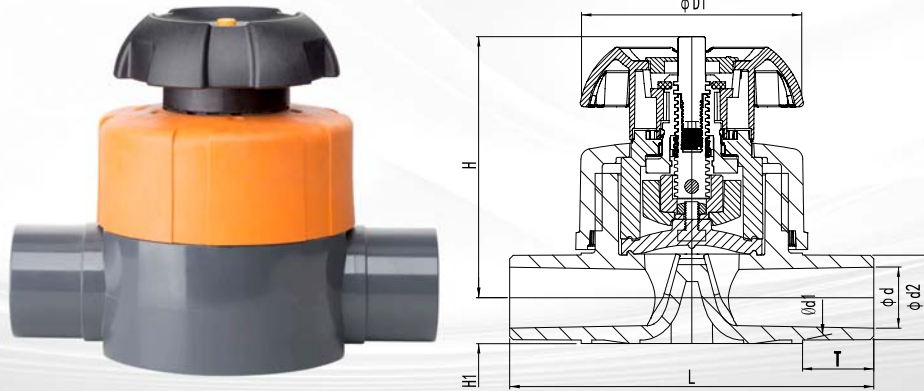

产品介绍

阀门描述 Valve description

- 1. 材质: PVC-U/C**
Material: PVC-U/C
- 2. 尺寸: DN15-50 1/2" -2"**
Size: DN15-50 1/2" -2"
- 3. 标准: 国标, 美标**
Standard: DIN, ASTM
- 4. 连接: 插口**
Connection: socket
- 5. 颜色: 本体灰色, 阀盖黄色, 手柄黑色**
Color: body gray, bonnet yellow, handle black

产品特性 Product Features

- 1. 开关扭力小**
Switch torque is small
- 2. 部件可更换, 简单经济**
Simple economy
- 3. 材料经过纳米改性, 提高产品的耐压性及抗冲击性**
The material is nano-modified to improve the pressure resistance and impact resistance of the product
- 4. 阀体加厚处理, 抗压性能高**
Thickened valve body for high compression resistance
- 5. 阀门出厂 100% 压力测试**
Valve factory 100% pressure test
- 6. 本体和密封经过特殊处理, 性能更好**
The body and seal are specially treated for better performance. Actuator performs 500,000 opening and closing tests

产品参数 (国标 DIN)

尺寸 Size DN(De)	外形尺寸 Dimensions (mm)							
	D1	d1	d2	d	H1	H	T	L
15(20)	65.00	20.30	19.95	20.10	14.00	90.00	16.50	124.00
20(25)	65.00	25.30	24.95	25.10	18.00	102.00	19.00	144.00
25(32)	93.50	32.30	31.90	32.10	21.00	119.00	22.50	154.00
32(40)	93.50	40.35	39.90	40.15	26.00	126.00	26.50	174.00
40(50)	121.00	50.35	49.90	50.15	33.00	139.00	31.50	194.00
50(63)	121.00	63.40	62.90	63.20	39.00	172.00	36.70	234.00

产品参数 (美标 ASTM SCH80)

尺寸 Size (*")	外形尺寸 Dimensions (mm)							
	D1	d1	d2	d	H1	H	T	L
1/2"	65.00	21.54	21.23	21.34	14.00	90.00	23.22	124.00
3/4"	65.00	26.87	26.57	26.67	18.00	102.00	26.40	144.00
1"	93.50	33.66	33.27	33.40	21.00	119.00	29.57	154.00
1-1/4"	93.50	42.42	42.04	42.16	26.00	126.00	32.75	174.00
1-1/2"	121.00	48.56	48.11	48.26	33.00	139.00	35.93	194.00
2"	121.00	60.63	60.17	60.33	39.00	172.00	39.10	234.00

序号 NO.	名称 Name	数量 Quantity	材料 Material
01	阀体 (国标) Body(DIN)	1	PVC-U/C
02	隔膜片 Diaphragm	1	EPDM/FPM
03	隔膜片封水套 Diaphragm water seal sleeve	1	PP+GF30
04	六角螺栓 Hex bolt	1	Stainless steel 304
05	六角螺母 Hex nut	1	Stainless steel 304
06	阀瓣嵌件 Disc insert	1	Brass (H62)
07	指示杆 (内外嵌件) Indicator stem(both insert)	1	PP
08	盖板 Cover	1	PP
09	卡簧 Jump ring	1	Spring steel
10	手轮 Handwheel	1	PP+GF30/PA6+GF30
11	阀体螺帽 Body nut	1	PA6+GF30
12	阀杆 Stem	1	Stainless steel 304
13	销钉 pins	1	Stainless steel 304
14	阀杆螺母嵌件 Stem screw insert	1	Brass (H62)
15	阀杆螺母 Stem screw	1	PPS
16	阀瓣 Disc	1	PPS

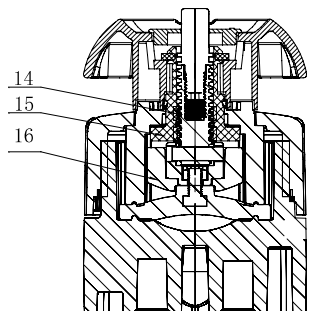
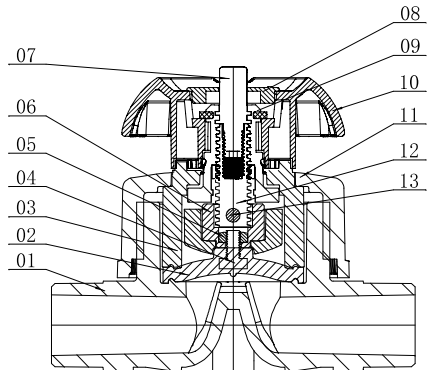
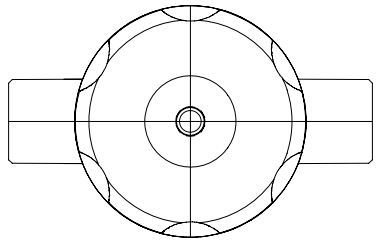

PVC-U/C TRUE UNION DIAPHRAGM VALVE

由令式插口隔膜阀, PVC-U/C (国标, 美标, 日标)

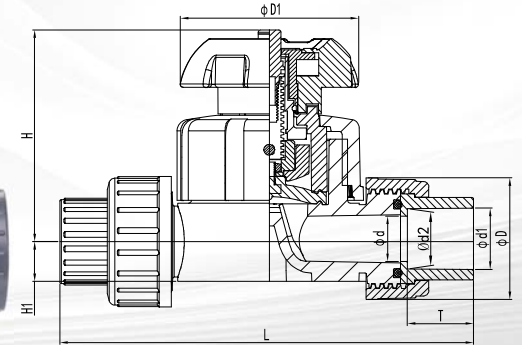

产品介绍

阀门描述

Valve description

1. 材质: PVC -U/C
Material: PVC -U/C
2. 尺寸: DN15-50 1/2" -2" 16A-50A
Size: DN15-50 1/2" -2" 16A-50A
3. 标准: 国标, 美标, 日标
Standard: DIN, ASTM, JIS
4. 连接: 插口
Connection: socket
5. 颜色: 本体灰色, 阀盖黄色, 手柄黑色
Color: body gray, bonnet yellow, handle black

产品特性

Product Features

1. 开关扭力小
Switch torque is small
2. 部件可更换, 简单经济
Parts can be replaced, simple and economical
3. 材料经过纳米改性, 提高产品的耐压性及抗冲击性
The material is nano-modified to improve the pressure resistance and impact resistance of the product
4. 阀体加厚处理, 抗压性能高
Thickened valve body for high compression resistance
5. 阀门出厂 100% 压力测试
Valve factory 100% pressure test

产品参数 (国标 DIN)

尺寸 Size DN(De)	外形尺寸 Dimensions (mm)								
	D	D1	d1	d2	d	H1	H	T	L
15(20)	46.50	65.00	20.30	19.95	16.00	14.00	90.00	16.50	128.00
20(25)	53.50	65.00	25.30	24.95	20.00	18.00	102.00	19.00	152.00
25(32)	64.00	93.50	32.30	31.90	26.00	21.00	119.00	22.50	166.00
32(40)	74.50	93.50	40.35	39.90	34.00	26.00	126.00	26.50	192.00
40(50)	85.00	121.00	50.35	49.90	43.00	33.00	139.00	31.50	222.00
50(63)	100.00	121.00	63.40	62.90	56.00	39.00	172.00	36.70	266.00

产品参数 (美标 ASTM SCH80)

尺寸 Size (*")	外形尺寸 Dimensions (mm)								
	D	D1	d1	d2	d	H1	H	T	L
1/2"	46.50	65.00	21.54	21.23	16.00	14.00	90.00	23.22	141.00
3/4"	53.50	65.00	26.87	26.57	20.00	18.00	102.00	26.40	166.80
1"	64.00	93.50	33.66	33.27	26.00	21.00	119.00	29.57	180.00
1-1/4"	74.50	93.50	42.42	42.04	34.00	26.00	126.00	32.75	204.00
1-1/2"	85.00	121.00	48.56	48.11	43.00	33.00	139.00	35.93	231.00
2"	100.00	121.00	60.63	60.17	56.00	39.00	172.00	39.10	272.00

产品参数 (日标 JIS)

尺寸 Size (*")	外形尺寸 Dimensions (mm)								
	D0	D1	d1	d2	d	H1	H	T	L
16	46.50	65.00	22.40	21.60	16.00	14.00	90.00	30.00	161.60
20	53.50	65.00	26.45	25.51	20.00	18.00	102.00	35.00	195.20
25	64.00	93.50	32.66	31.50	26.00	21.00	119.00	40.00	209.80
30	74.50	93.50	38.60	37.43	34.00	26.00	126.00	44.00	237.60
40	85.00	121.00	48.85	47.38	43.00	33.00	139.00	55.00	280.00
50	100.00	121.00	61.00	59.27	56.00	39.00	172.00	63.00	328.00

序号 NO.	名称 Name	数量 Quantity	材料 Material
01	承口螺帽 Faucet nut	1	PVC-U/C
02	O 型圈 O-ring	1	EPDM/FPM
03	承口 (国标) Faucet(DIN)	1	PVC-U/C
04	阀体 (国标) Body(DIN)	1	PVC-U/C
05	隔膜片 Diaphragm	1	EPDM/FPM
06	隔膜片封水套 Diaphragm water seal sleeve	1	PP+GF30
07	六角螺栓 Hex bolt	1	Stainless steel 304
08	六角螺母 Hex nut	1	Stainless steel 304
09	阀瓣嵌件 Disc insert	1	Brass (H62)
10	指示杆 (内外嵌件) Indicator stem(both insert)	1	PP
11	手轮 Handwheel	1	PP+GF30/PA6+GF30
12	阀体螺帽 Body nut	1	PA6+GF30
13	阀杆 Stem	1	Stainless steel 304
14	销钉 pins	1	Stainless steel 304
15	盖板 Cover	1	PP
16	卡簧 Jump ring	1	Spring steel
17	阀杆螺母嵌件 Stem screw insert	2	Brass (H62)
18	阀杆螺母 Stem screw	1	PPS
19	阀瓣 Disc	1	PPS

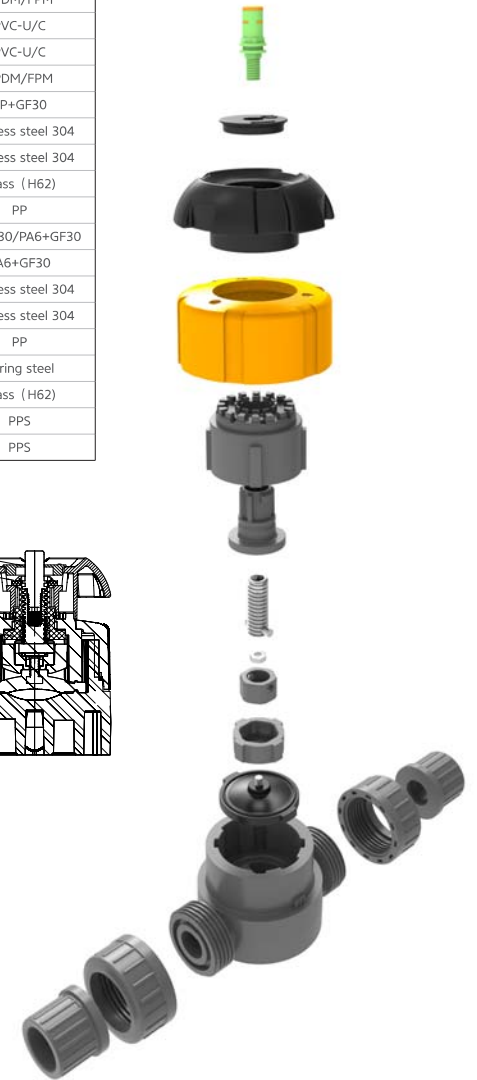
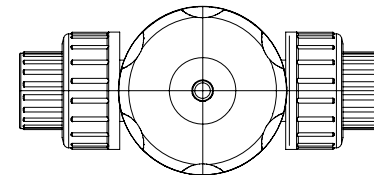
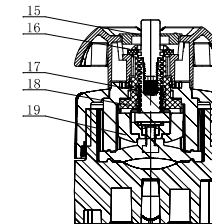
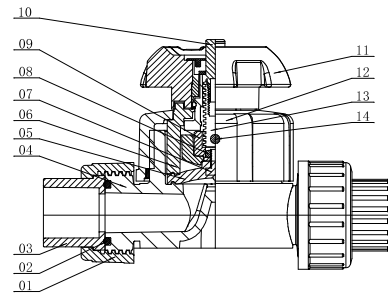

PVC-U/C SOCKET TRUE UNION CHECK VALVE

插口式双由令止回阀, PVC-U/C (国标, 美标, 日标)

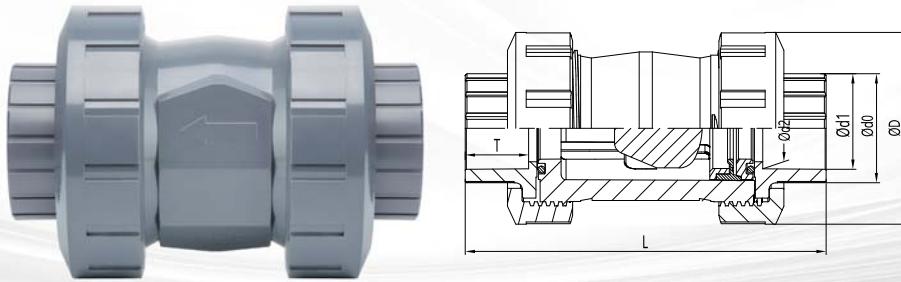

产品介绍

阀门描述 Valve description

1. 材质: PVC-U/C
Material: PVC-U/C
2. 尺寸: DN15-100 1/2" -4" 16A-100A
Size: DN15-100 1/2" -4" 16A-100A
3. 标准: 国标, 美标, 日标
Standard: DIN, ASTM, JIS
4. 连接: 插口
Connection: socket
5. 颜色: 深灰
Color: dark gray

产品特性 Product Features

1. 部件可更换, 简单经济
Simple economy
2. 材料经过纳米改性, 提高产品的耐压性及抗冲击性
The material is nano-modified to improve the pressure resistance and impact resistance of the product
3. 阀体加厚处理, 抗压性能高
Thickened valve body for high compression resistance
4. 阀门出厂 100% 压力测试
Valve factory 100% pressure test
5. 本体和密封经过特殊处理, 性能更好
The body and seal are specially treated for better performance. Actuator performs 500,000 opening and closing tests

产品参数 (国标 DIN)

尺寸 Size DN(De)	外形尺寸 Dimensions (mm)						公称压力 Nominal Pressure PN(kg/cm ²)
	D	d0	d1	d2	T	L	
15(20)	51.50	27.40	20.30	19.95	17.00	95.80	PN10
20(25)	59.00	32.70	25.30	24.95	19.50	109.60	PN10
25(32)	70.00	41.30	32.30	31.90	23.00	123.10	PN10
32(40)	85.40	49.60	40.35	39.90	27.00	150.00	PN10
40(50)	98.90	60.20	50.35	49.90	32.00	161.20	PN10
50(63)	122.20	76.00	63.40	62.90	38.50	186.00	PN10
65(75)	158.60	89.60	75.40	74.90	44.50	236.00	PN10
80(90)	192.10	105.40	90.50	89.90	52.00	255.00	PN10
100(110)	223.60	128.40	110.60	109.90	62.00	298.60	PN10

产品参数 (美标 ASTM SCH80)

尺寸 Size (*")	外形尺寸 Dimensions (mm)					
	D	d0	d1	d2	T	L
1/2"	51.50	27.40	21.54	21.23	23.30	108.40
3/4"	59.00	32.70	26.87	26.57	26.50	123.60
1"	70.00	41.30	33.66	33.27	29.70	136.50
1-1/4"	85.40	49.60	42.42	42.04	32.90	161.80
1-1/2"	98.90	60.20	48.56	48.11	36.10	169.40
2"	122.20	76.00	60.63	60.17	39.30	187.60
2-1/2"	158.60	89.60	73.38	72.85	45.70	237.20
3"	192.10	105.40	89.31	88.70	48.90	248.80
4"	223.60	128.40	114.76	114.07	58.40	291.40

产品参数 (日标 JIS)

尺寸 Size A	外形尺寸 Dimensions (mm)						公称压力 Nominal Pressure PN(kg/cm ²)
	D	d0	d1	d2	T	L	
16	51.50	30.50	22.40	21.60	30.00	121.80	PN10
20	59.00	34.11	26.45	25.51	35.00	140.60	PN10
25	70.00	41.30	32.66	31.50	40.00	157.10	PN10
30	85.40	48.16	38.60	37.43	44.00	184.00	PN10
40	98.90	59.10	48.85	47.38	55.00	207.20	PN10
50	122.20	72.10	61.00	59.27	63.00	235.00	PN10
65	158.60	89.23	77.10	75.73	63.00	273.00	PN10
75	192.10	105.33	89.60	88.58	64.00	279.00	PN10
100	223.60	133.07	114.70	113.55	84.00	342.60	PN10

序号 NO.	名称 Name	数量 Quantity	材料 Material
01	承口 Faucet	2	PVC-U/C
02	螺帽 Nut	2	PVC-U/C
03	阀体 Body	1	PVC-U/C
04	垫圈 Washer	1	PVC-U/C
05	橡胶圈 Rubber ring	1	EPDM/FPM
06	定位圈 Location Ring	1	PVC-U/C
07	球心 Ball	1	PVC-U/C
08	O型圈 O-Ring	2	EPDM/FPM

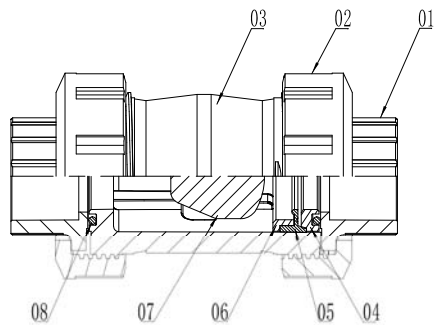

PVC-U/C THREADED TRUE UNION CHECK VALVE

丝口式双由令止回阀, PVC-U/C (国标, 美标, 日标)

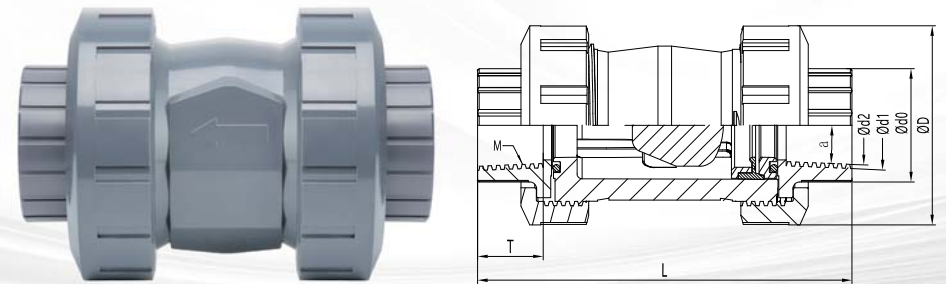

产品介绍

阀门描述

Valve description

1. 材质: PVC-U/C
Material: PVC-U/C
2. 尺寸: DN15-100 1/2" -4" 16A-100A
Size: DN15-100 1/2" -4" 16A-100A
3. 标准: 国标, 美标, 日标
Standard: DIN, ASTM, JIS
4. 连接: 丝口
Connection: Threaded
5. 颜色: 深灰
Color: dark gray

产品特性

Product Features

1. 部件可更换, 简单经济
Simple economy
2. 材料经过纳米改性, 提高产品的耐压性及抗冲击性
The material is nano-modified to improve the pressure resistance and impact resistance of the product
3. 阀体加厚处理, 抗压性能高
Thickened valve body for high compression resistance
4. 阀门出厂 100% 压力测试
Valve factory 100% pressure test
5. 本体和密封经过特殊处理, 性能更好
The body and seal are specially treated for better performance. Actuator performs 500,000 opening and closing tests

产品参数 (国标 DIN)

尺寸 Size DN(De)	外形尺寸 Dimensions (mm)								公称压力 Nominal Pressure PN(kg/cm ²)
	D	d0	d1	d2	T	L	Tr 螺纹	a	
15(20)	51.50	27.40	20.95	18.63	17.00	95.80	1/2"	3.58	PN10
20(25)	59.00	32.70	26.44	24.12	19.50	109.58	3/4"	3.58	PN10
25(32)	70.00	41.30	33.25	30.29	23.00	123.10	1"	3.58	PN10
32(40)	85.40	49.60	41.91	38.95	27.00	147.50	1-1/4"	3.58	PN10
40(50)	98.90	60.20	47.80	44.85	32.00	159.50	1-1/2"	3.58	PN10
50(63)	122.20	76.00	59.61	56.66	38.50	184.80	2"	3.58	PN10
65(75)	158.60	89.60	75.18	74.23	44.50	233.50	2-1/2"	3.58	PN10
80(90)	192.10	105.40	87.88	84.93	52.00	255.00	3"	3.58	PN10
100(110)	223.60	128.40	113.03	110.07	62.00	297.50	4"	3.58	PN10

产品参数 (美标 ASTM SCH80)

尺寸 Size (*")	外形尺寸 Dimensions (mm)								公称压力 Nominal Pressure PN(kg/cm ²)
	D	d0	d1	d2	T	L	Tr 螺纹	a	
1/2"	51.50	27.40	20.95	18.63	17.00	95.80	1/2"	3.58	PN10
3/4"	59.00	32.70	26.44	24.12	19.50	109.58	3/4"	3.58	PN10
1"	70.00	41.30	33.25	30.29	23.00	123.10	1"	3.58	PN10
1-1/4"	85.40	49.60	41.91	38.95	27.00	147.50	1-1/4"	3.58	PN10
1-1/2"	98.90	60.20	47.80	44.85	32.00	159.50	1-1/2"	3.58	PN10
2"	122.20	76.00	59.61	56.66	38.50	184.80	2"	3.58	PN10
2-1/2"	158.60	89.60	75.18	74.23	44.50	233.50	2-1/2"	3.58	PN10
3"	192.10	105.40	87.88	84.93	52.00	255.00	3"	3.58	PN10
4"	223.60	128.40	113.03	110.07	62.00	297.50	4"	3.58	PN10

产品参数 (目标 JIS)

尺寸 Size A	外形尺寸 Dimensions (mm)								公称压力 Nominal Pressure PN(kg/cm ²)
	D	d0	d1	d2	T	L	Tr 螺纹	a	
16	51.50	27.40	20.95	18.63	17.00	95.80	1/2"	3.58	PN10
20	59.00	32.70	26.44	24.12	19.50	109.58	3/4"	3.58	PN10
25	70.00	41.30	33.25	30.29	23.00	123.10	1"	3.58	PN10
30	85.40	49.60	41.91	38.95	27.00	147.50	1-1/4"	3.58	PN10
40	98.90	60.20	47.80	44.85	32.00	159.50	1-1/2"	3.58	PN10
50	122.20	76.00	59.61	56.66	38.50	184.80	2"	3.58	PN10
65	158.60	89.60	75.18	74.23	44.50	233.50	2-1/2"	3.58	PN10
75	192.10	105.40	87.88	84.93	52.00	255.00	3"	3.58	PN10
100	223.60	128.40	113.03	110.07	62.00	297.50	4"	3.58	PN10

序号 NO.	名称 Name	数量 Quantity	材料 Material
01	承口 Faucet	2	PVC-U/C
02	螺帽 Nut	2	PVC-U/C
03	阀体 Body	1	PVC-U/C
04	垫圈 Washer	1	PVC-U/C
05	橡胶圈 Rubber ring	1	EPDM/FPM
06	定位圈 Location Ring	1	PVC-U/C
07	球心 Ball	1	PVC-U/C
08	O 型圈 O-Ring	2	EPDM/FPM

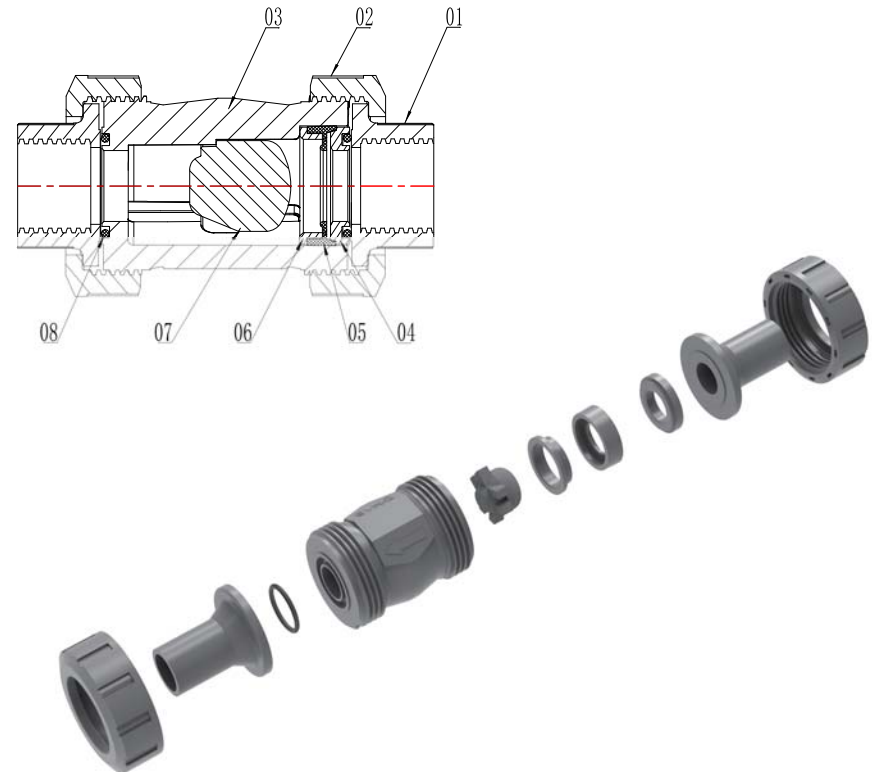

PVC-U/C FLANG TRUE UNION CHECK VALVE 法兰式双由令止回阀, PVC-U/C (国标)

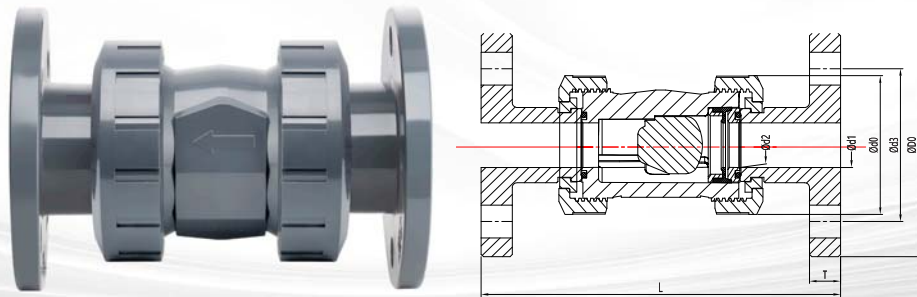

产品介绍

阀门描述 Valve description

1. 材质: PVC-U/C
Material: PVC-U/C
2. 尺寸: DN15-100
Size: DN15-100
3. 标准: 国标
Standard: DIN
4. 连接: 法兰式
Connection: Flanged
5. 颜色: 深灰
Color: dark gray

产品特性 Product Features

1. 部件可更换, 简单经济
Simple economy
2. 材料经过纳米改性, 提高产品的耐压性及抗冲击性
The material is nano-modified to improve the pressure resistance and impact resistance of the product
3. 阀体加厚处理, 抗压性能高
Thickened valve body for high compression resistance
4. 阀门出厂 100% 压力测试
Valve factory 100% pressure test
5. 本体和密封经过特殊处理, 性能更好
The body and seal are specially treated for better performance. Actuator performs 500,000 opening and closing tests

产品参数 (国标 DIN)

尺寸 Size Dn(De)	外形尺寸 Dimensions (mm)							公称压力 Nominal Pressure PN(kg/cm ²)
	D0	d0	d1	d2	d3	T	L	
15(20)	95.00	51.50	20.30	19.95	65.00	13.00	141.60	10
20(25)	105.00	59.00	25.30	24.95	75.00	14.00	171.50	10
25(32)	115.00	70.00	32.30	31.90	85.00	15.00	188.50	10
32(40)	140.00	85.40	40.35	39.90	100.00	15.00	187.50	10
40(50)	150.00	98.90	50.35	49.90	110.00	17.00	215.00	10
50(63)	165.00	122.20	63.40	62.90	125.00	17.00	235.00	10
65(75)	185.00	158.60	75.40	74.90	145.00	18.00	288.50	10
80(90)	200.00	192.10	90.50	89.90	160.00	18.00	310.00	10
100(110)	220.00	223.60	110.60	109.90	180.00	18.00	375.00	10

EXPERT IN PIPING SYSTEM

管路系统的专家级工厂



序号 NO.	名称 Name	数量 Quantity	材料 Material
01	法兰头 Flange	2	PVC-U/PVC-C
02	螺帽 Nut	2	PVC-U/PVC-C
03	阀体 Body	1	PVC-U/PVC-C
04	固定卡环 Clamp Ring	2	PVC-U/PVC-C
05	垫圈 Washer	1	PVC-U/PVC-C
06	橡胶圈 Rubber Ring	1	EPDM/FPM
07	定位圈 Located Ring	1	PVC-U/PVC-C
08	球芯 Ball	1	PVC-U/PVC-C
09	O型圈 O-ring	2	EPDM/FPM

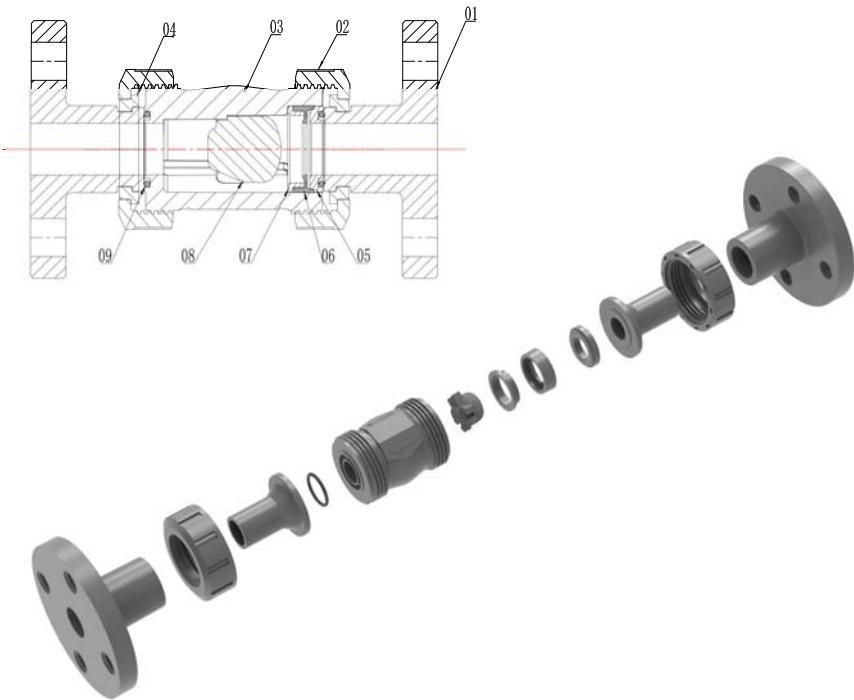

PVC-U/C SWING SPRING CHECK VALVE

旋启式止回阀, PVC-U/C (国标, 美标, 日标)

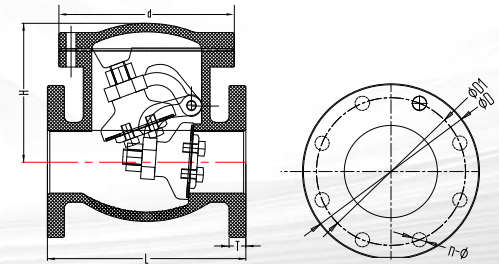

产品介绍

阀门描述 Valve description

1. 材质: PVC-U/C
Material: PVC-U/C
2. 尺寸: DN15-200 1/2" -8" 16A-200A
Size: DN15-200 1/2" -8" 16A-200A
3. 标准: 国标, 美标, 日标
Standard: DIN, ASTM, JIS
4. 连接: 法兰
Connection: Flanged
5. 颜色: 深灰
Color: dark gray

产品特性 Product Features

1. 部件可更换, 简单经济
Simple economy
2. 材料经过纳米改性, 提高产品的耐压性及抗冲击性
The material is nano-modified to improve the pressure resistance and impact resistance of the product
3. 阀体加厚处理, 抗压性能高
Thickened valve body for high compression resistance
4. 阀门出厂 100% 压力测试
Valve factory 100% pressure test
5. 本体和密封经过特殊处理, 性能更好
The body and seal are specially treated for better performance. Actuator performs 500,000 opening and closing tests

产品参数 (国标 DIN)

尺寸 Size DN	外形尺寸 Dimensions (mm)							公称压力 Nominal Pressure PN(kg/cm ²)
	D	D1	L	T	H	d	n-φe	
15	100	65	140	15	93	87	4-φ14	PN10
20	100	75	140	15	93	87	4-φ14	PN10
25	120	85	160	15	117	130	4-φ18	PN10
32	140	100	180	19	137	146	4-φ18	PN10
40	140	110	180	19	137	146	4-φ18	PN8
50	165	125	200	20	156	167	4-φ18	PN8
65	185	145	240	22	170.2	203	4-φ18	PN8
80	200	160	260	22	181	230	8-φ18	PN5
100	224	180	300	24	216	278	8-φ18	PN5
125	254	210	300	24	216	278	8-φ18	PN5
150	285	240	400	26	286	394	8-φ23	PN5
200	324	295	500	30	336	476	8-φ23	PN3

产品参数 (美标 ASTM SCH80)

尺寸 Size (")	外形尺寸 Dimensions (mm)							公称压力 Nominal Pressure PN(kg/cm ²)
	D	D1	L	T	H	d	n-φe	
1/2"	100	60	140	15	93	87	4-φ16	PN10
3/4"	100	70	140	15	93	87	4-φ16	PN10
1"	120	79	160	15	117	130	4-φ16	PN10
1-1/4"	140	88.9	180	19	137	146	4-φ16	PN10
1-1/2"	140	98	180	19	137	146	4-φ16	PN8
2"	165	121	200	20	156	167	4-φ19	PN8
2-1/2"	185	140	240	22	170.2	203	4-φ19	PN8
3"	200	152	260	22	181	230	4-φ19	PN5
4"	224	191	300	24	216	278	8-φ19	PN5
5"	254	216	300	24	216	278	8-φ22	PN5
6"	285	241	400	26	286	394	8-φ22	PN5
8"	324	298	500	30	336	476	8-φ22	PN3

产品参数 (目标 JIS)

尺寸 Size A	外形尺寸 Dimensions (mm)							公称压力 Nominal Pressure PN(kg/cm ²)
	D	D1	L	T	H	d	n-φe	
16	100	70.00	140	15	93	87	4-φ15	PN10
20	100	75.00	140	15	93	87	4-φ15	PN10
25	120	90.00	160	15	117	130	4-φ19	PN10
30	140	100.00	180	19	137	146	4-φ19	PN10
40	140	105.00	180	19	137	146	4-φ19	PN8
50	165	120.00	200	20	156	167	4-φ19	PN8
65	185	140.00	240	22	170.2	203	4-φ19	PN8
75	200	150.00	260	22	181	230	8-φ19	PN5
100	224	175.00	300	24	216	278	8-φ19	PN5
125	254	210.00	300	24	216	278	8-φ23	PN5
150	285	240.00	400	26	286	394	8-φ23	PN5
200	343	290.00	500	30	336	476	12-φ23	PN3

序号 NO.	名称 Name	数量 Quantity	材料 Material
01	端盖 End Cover	1	PVC-U/C
02	垫片 1 Gasket 1	1	EPDM/FPM
03	阀体 Body	1	PVC-U/C
04	铰链 Hinge	1	PVC-U/C
05	销钉 Pin	1	PTFE
06	六角螺栓 Hexagon Bolt	1—4	PVC-U/C
07	盖板 Coverplate	1	PVC-U/C
08	垫片 2 Gasket 2	1	EPDM/FPM
09	活板 Flap	1	PVC-U/C
10	螺帽 Nut	1	PVC-U/C
11	六角螺帽 Hexagon Nut	8—12	Stainless steel 304
12	弹垫 Spring Washer	8—12	Stainless steel 304
13	平垫 Plain Washer	16—24	Stainless steel 304
14	六角螺栓 Hexagon Bolt	8—12	Stainless steel 304

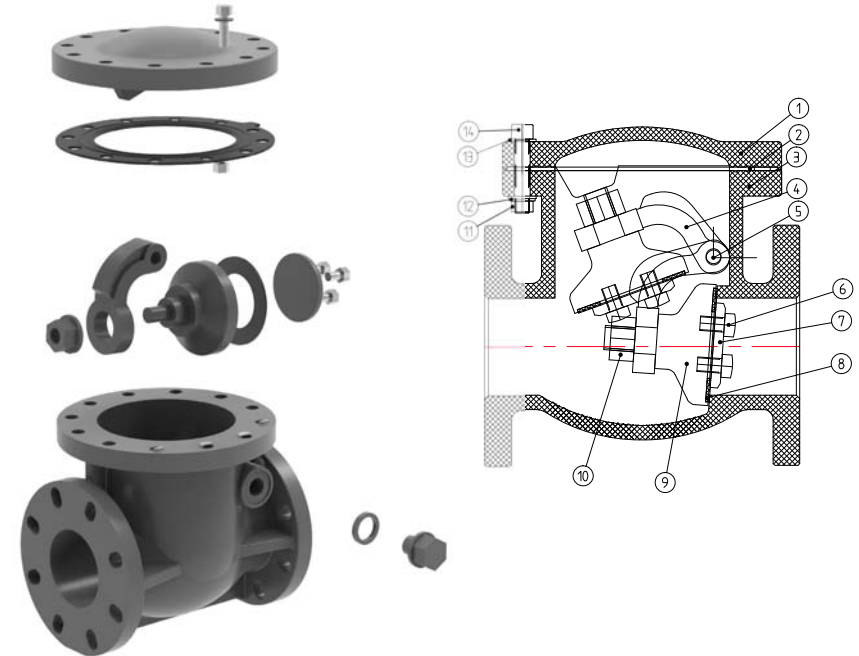

EXPERT IN PIPING SYSTEM

管路系统的专家级工厂



微信公众号二维码



企业网站二维码

 **400-928-1588**

华生管道科技有限公司

地址：常州市新北区空港产业园旺贤路9号(213133)
电话：+86 519-85201808 83201080
传真：+86 519-83201088 83201026
邮箱：sales@czuasheng.com
info@czuasheng.com
网址：www.czuasheng.com

HUASHENG PIPELINE TECHNOLOGY CO., LTD

Add: NO9, Wangxian Road, Konggang Industry Park, Xinbei District, Changzhou, 213133, China
Tel: +86 519-85201808 83201080
Fax: +86 519-83201088 83201026
Email: sales@czuasheng.com
info@czuasheng.com
Web: www.huashengpipe.com

©华生管道科技有限公司拥有该资料著作权及相关权利，未经权利人许可，不得擅自复制、发布、改编、或者向公众传播。
Huasheng Pipeline Technology Co.,Ltd. owns copyright and related rights, and the data, without the consent of the obligee shall not, without copying, Distribution, adapted, or transmitted to the public.