

# PVDF-UHP

管材 / 管件 / 阀门 PIPE / FITTING / VALVE

EXPERT IN PIPING SYSTEM  
管路系统的专家级工厂



微信公众号二维码



企业网站二维码

24h 400-928-1588

## 华生管道科技有限公司

地址：常州市新北区空港产业园旺盛路9号(213133)  
电话：+86 519-85201808 83201080  
传真：+86 519-83201088 83201026  
邮箱：sales@czhuasheng.com  
claire@czhuasheng.com  
网址：www.czhuasheng.com

## HUASHENG PIPELINE TECHNOLOGY CO., LTD

Add: NO.9, Wangxian Road, Konggang Industry Park, Xinbei District, Changzhou, 213133, China  
Tel: +86 519-8520180 883201080  
Fax: +86 519-83201088 83201026  
Email: sales@czhuasheng.com  
claire@czhuasheng.com  
Web: www.huashengpipe.com

© 华生管道科技有限公司拥有该资料著作权及相关权利，未经权利人许可，不得擅自复制、发布、改编或者向公众传播。  
Huasheng Pipeline Technology Co., Ltd owns the copyright and related rights of the data and it is not allowed to copy, publish, adapt or disseminate it to the public without the permission of the right holder.

HS-YB-220301



华生管道科技有限公司  
HUASHENG PIPELINE TECHNOLOGY CO., LTD

www.czhuasheng.com  
www.huashengpipe.com

# CONTENTS

## 目录

ABOUT US 关于我们	02
CERTIFICATIONS 资质证书	03
PRODUCT CATEGORY 产品类别	05
APPLICATIONS 行业应用	06
PIPE FITTING 管件	11

PVDF 高纯型对焊 90°弧形弯头 PVDF-UHP BUTT FUSION ELBOW 90°	12
PVDF 高纯型对焊 45°弯头 PVDF-UHP BUTT FUSION ELBOW 45°	13
PVDF 高纯型对焊 90°正三通 PVDF-UHP BUTT FUSION 90° TEE	14
PVDF 高纯型对焊 90°异三通 PVDF-UHP BUTT FUSION REDUCING TEE	15
PVDF 高纯型对焊 管帽 PVDF-UHP BUTT FUSION CAP	16
PVDF 高纯型对焊 异径 PVDF-UHP BUTT FUSION REDUCER	17
PVDF 高纯型对焊 法兰适配器 PVDF-UHP BUTT FUSION FLANGE ADAPTER	18
支撑法兰, 钢衬PP PP-STEEL BACKING FLANGE	19
PVDF 高纯型对焊 适配接头 PVDF-UHP BUTT FUSION MALE ADAPTOR	20
PVDF 高纯型对焊 适配缩节 PVDF-UHP BUTT FUSION FEMALE ADAPTOR	21
PVDF 高纯型对焊 活接 PVDF-UHP BUTT FUSION UNION	22
PVDF转PFA接头 PVDF TO PFA ADAPTOR	23
仪表接头 INSTRUMENT CONNECTOR	24

PIPE 高纯型—产品规格	07
------------------	----

PIPE 进口原料聚偏二氟乙烯 (PVDF) 高纯含氟聚合物	08
-----------------------------------	----

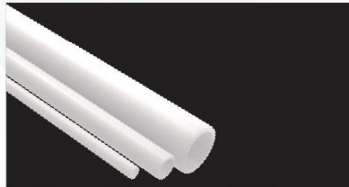

PIPE 管材	09
------------	----



## 25

## VALVE 阀门



PVDF 高纯型对焊 双由任球阀 PVDF-UHP BUTT FUSION TRUE UNION BALL VALVE	26
PVDF 高纯型对焊 全塑气动双由任球阀 PVDF-UHP BUTT FUSION PLASTIC PNEUMATIC TRUE UNION BALL VALVE	27
PVDF 高纯型对焊 由令式隔膜阀 PVDF-UHP TRUE UNION DIAPHRAGM VALVE BUTT FUSION TYPE	28
PVDF 高纯型对焊 隔膜阀 PVDF-UHP BUTT FUSION DIAPHRAGM VALVE	29
PVDF 高纯型法兰式 隔膜阀 PVDF-UHP FLANGED DIAPHRAGM VALVE	30
PVDF 高纯型对焊 全塑气动由令隔膜阀 PVDF-UHP TRUE UNION PNEUMATIC DIAPHRAGM VALVE BUTT FUSION TYPE	31
PVDF 高纯型对焊 全塑气动隔膜阀 PVDF-UHP BUTT FUSION PLASTIC PNEUMATIC DIAPHRAGM VALVE	32
PVDF 高纯型对焊 T型手动隔膜阀 PVDF-UHP BUTT FUSION T-DIAPHRAGM VALVE(MANUAL)	33
PVDF 高纯型对焊 T型异径手动隔膜阀 PVDF-UHP BUTT FUSION REDUCING T-DIAPHRAGM VALVE(MANUAL)	34
PVDF 高纯型对焊 T型气动隔膜阀 PVDF-UHP BUTT FUSION T-DIAPHRAGM VALVE (PNEUMATIC)	35
PVDF 高纯型对焊 T型异径气动隔膜阀 PVDF-UHP BUTT FUSION REDUCING T-DIAPHRAGM VALVE (PNEUMATIC)	36
PVDF 高纯型对焊 电动由令式隔膜阀 PVDF-UHP TRUE UNION ELECTRIC DIAPHRAGM VALVE BUTT FUSION TYPE	37

Professional strength  
builds easy life

专业实力构筑轻松生活



# PVDF-UHP 管材/管件/阀门

## PVDF-UHP PIPE/FITTING/VALVE

# EXPERT IN PIPING SYSTEM

## 管路系统的专家级工厂

重信求实 华生企业的灵魂  
开拓创新 永恒发展的动力

以质取胜、以质取信，为顾客提供满意的产品和服务。



# ABOUT US

## 关于我们

### ▶ 公司简介 / Company Introduction

华生管道科技有限公司始建于 1988 年，坐落于江苏常州高新技术产业开发区，是一家集 UPVC、CPVC、PE、PPH、PVDF、PVDF-UHP、PFA、AGR、PVC-UH 等材质的工业给水、环保水处理设备类塑料管道产品研发、制造于一体的管路系统专业生产企业。同时也是测量与控制仪表的专业的生产企业。经过多年的探索与提升，目前华生已成为行业内的领先企业，是江苏省塑料管道系统工程技术中心依托单位，中国塑料加工工业协会塑料管道专业委员会成员单位，中国电子材料行业协会成员单位。

Huasheng Pipeline Technology Co., Ltd has been in business since 1988. The company is located in Changzhou High-Tech Industrial Development Zone, Jiangsu Province.

Huasheng is a professional pipeline system enterprise who is engaged in researching, developing and manufacturing all kinds of UPVC, CPVC, PE, PPH, PVDF, PVDF-UHP, PFA, AGR, PVC-UH piping systems for industrial, water supply and water treatment applications. Moreover, it is also a specialized manufacturer of measurement and control instrumentation.

After years of exploration and improvement, now Huasheng is one of the leading enterprises in the industry: It is the supporting and sponsoring institution of Jiangsu Engineering Research Center for Plastic System, the member of the professional board of China Plastic Processing Industry Association (CPPIA), the member of China Electronics Materials Industry Association (CEMIA).

### ▶ 公司实力 / Company Strength

公司占地面积 20 万平方米，拥有固定资产 6 亿元人民币。公司现有员工 400 多人，下设模具事业部、管路系统事业部、精密注塑事业部，原料混配系统 10 套，造粒生产线 12 条，管材挤出生产线 30 条，注塑机 200 多台，大型加工中心等机械加工设备 80 多台，万级洁净厂房超过 7800 平方米，百级洁净厂房 200 平方米，专用于 PVDF、PVDF-UHP、仪表的生产和检测。塑料管路年生产能力达 80000 吨。测量与控制仪表年生产能力超过 10000 套。

Huasheng Co., Ltd operates two modern factories of 200,000 square meters with fixed assets of 600 million yuan. The company has more than 400 employees and consists of mold division, piping system division, and precision injection molding division.

Huasheng owns 10 sets of raw material mixing systems, 12 granulation production lines, 30 pipe extrusion production lines, and more than 200 injection molding machines, over 80 sets of mechanical processing equipment such as large-scale machining centers, more than 7,800 m<sup>2</sup> of class 10,000 (ISO 14644-1 Class 7) cleanroom, and 200 m<sup>2</sup> of class 100 (ISO 14644-1 Class 5) cleanroom, dedicated to the production and testing of PVDF, PVDF-UHP, and instrumentation.

The annual production capacity of plastic piping system is 80,000 tons. The annual production capacity of measuring and control instrumentation exceeds 10,000 sets.

### ▶ 资质和荣誉 / Qualifications and Awards

目前公司已经通过 ISO9001、ISO14001、ISO45001 等体系的认证，以及美国卫生基金会国际组织 NSF 认证。公司被认定为江苏省高新技术企业，“华生”商标荣获江苏省著名商标。拥有江苏省高新技术产品 6 项，授权专利 47 项，获得江苏省市场监督管理局颁发的《中华人民共和国特种设备制造许可证（压力管道元件）》和江苏省卫生健康委员会颁发的《涉水产品卫生行政许可批件》。

The company owns ISO9001, ISO14001, ISO45001 and other system certifications, as well as the US national sanitation foundation (NSF) certification. The company has been recognized as a high-tech enterprise of Jiangsu Province and the "Huasheng" trademark has been awarded as a famous Jiangsu trademark by Jiangsu Provincial Government. Huasheng owns 6 high-tech products of Jiangsu Province and 47 authorized patents. In addition, the company has obtained the "Manufacturing License for Special Equipment of the People's Republic of China (Pressure Pipeline Components)" issued by the Jiangsu Provincial Administration for Market Regulation and the "Administrative License for Sanitation of Water-related Products" issued by the Jiangsu Commission of Health (former Jiangsu Provincial Health and Family Planning Commission).

# CERTIFICATIONS

## 资质证书

客户至上，优质高效，绿色环保，顾客满意。

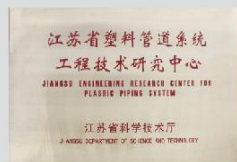
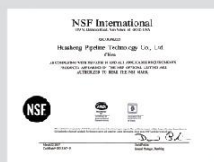
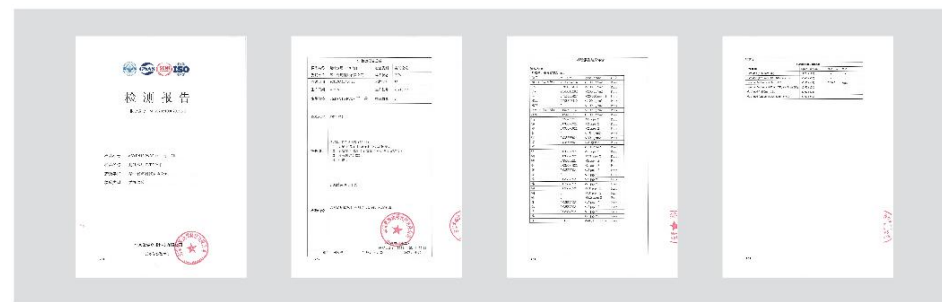
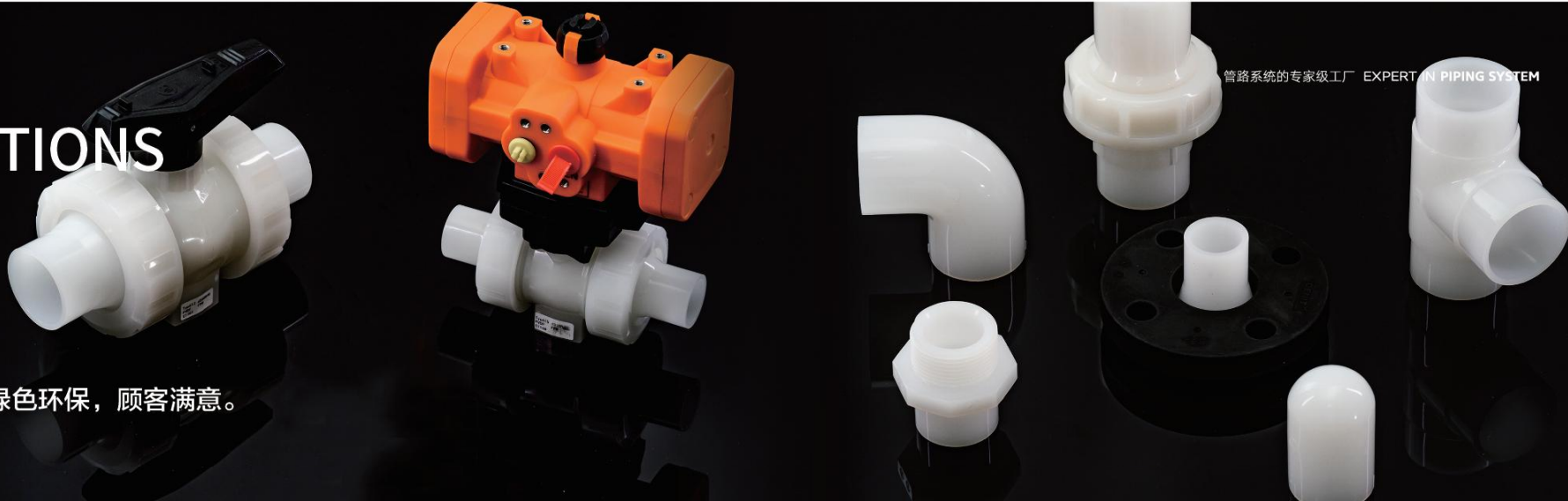

# PRODUCT CATEGORY

## 产品类别

### ▶ 管材 PIPE

管材 PIPE



管材 PIPE

### ▶ 管件 PIPE FITTING

管件 PIPE FITTING



管件 PIPE FITTING

### ▶ 阀门 VALVE

阀门 VALVE



阀门 VALVE

# APPLICATIONS

## 行业应用



管路系统的专家级工厂 EXPERT IN PIPING SYSTEM

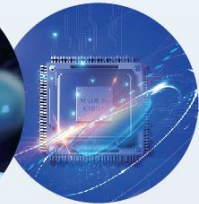

▪ 食品    ▪ 医疗    ▪ 半导体行业



## PVDF-UHP – SPECIFICATIONS

### 高纯型—产品规格

材质 Material	高纯聚偏二氟乙烯 (PVDF) PVDF-UHP
颜色 Color	纯粹原料.半透明 Pure raw materials, translucent
密度 Density	-1.78g/cm <sup>3</sup> (ISO 1183/ASTM D 792)
表面张力 Surface Tension	30-35mJ/m <sup>2</sup>
线膨胀系数 Coefficient of linear expansion	0.12-0.18mm/mK (DIN 53752)
弹性模量 (抗张强度) Tensile strength	2100N/mm <sup>2</sup> (ISO 527/ASTMD 790)
热导系数 Thermal conductivity	0.19W/mK(DIN 52612)
表面阻抗 Surface impedance	5 x 1014 Ω cm (IEC 60093)
尺寸 Size	d20 (1/2") -d280 (10") 符合ISO 10931标准 Meet ISO 10931 Standard
压力等级 Pressure	管子/管件: PN16(d20-d225).PN10(d90-d280).阀门: 参见各自独立规格 Pipe / fitting: PN16 (d20-d225) PN10(d90-d280). Valves: see Individual specifications
温度范围 Temperature range	从-20℃到140℃ (-4°F到284°F)
生产 Manufacturing	管件/隔膜阀: 注塑产品.管子: 挤塑产品 在ISO14644-1标准的7级 (即美国联邦209E标准10000级) 洁净厂房内生产, 随后的装配, 质量检验和18M纯水的清洗过程均是在ISO14644-1标准的5级 (即美国联邦209E标准100级) 洁净厂房内进行。 Pipe fittings / diaphragm valves: injection molded products Pipe: extruded products All products are produced in a clean workshop of ISO14644-1 class 7 (OR, the US Federal 209E standard 10000), and the subsequent assembly, quality inspection and 18M pure water cleaning process are all in the ISO14644-1 standard class 5 (OR, the US Federal 209E Standard 100) clean workshop.
表面光洁度 Surface finish	内表面的225Ra≤0.2 μm (9 μin) / >d225Ra≤0.3 μm (12 μin) 适应于注塑产品和挤塑产品
标识 Identification	所有产品均在生产时模压刻有永久性标识符以保证完全的可追溯性。 All products are molded and engraved with permanent identifiers during production to ensure complete traceability. 批号 Batch number 材料名称 Material Name 尺寸 Size 压力等级 Pressure
测试与检查 Testing and inspection	掺杂物 Dopant 目测 Visual Inspection 表面光洁度 Surface Finish 尺寸公差 Dimensional Tolerance 打压试验 Pressure Test 周期性析出物, 根据SEMI协会F40/F57标准 Periodic precipitates, according to SEMI F40 / F57 standard

#### 焊接技术 Welding

红外焊接,(符合DVS 2207-6标准), 尺寸范围: d20 (1/2") -d280 (10")  
Infrared welding, (DVS 2207-6 Standard), size range: D20 (1/2") - D280 (10")

#### 包装 Packaging

管子两端带帽, 每一个产品均为独立双层包装, 第一层为特定用袋, 第二层护套管。  
Both ends of the pipe have caps. Each product is packaged in independent double layers. The first layer is a special design-bag and the second layer is Protective sleeve.

#### 标签 Label

商标名 Trade Name  
产品描述 Product Description  
材料 Material  
尺寸 Size

#### 主要应用 Applications

用途包括半导体工业超纯水输送系统, 制药级纯水 (如注射剂用水/纯水) 和分析实验用去离子水到最高纯度要求纯水, 可采用多种消毒方法, 如臭氧消毒法, 热水消毒法或蒸汽消毒法。  
Applications: Including ultra-pure water delivery systems for the semiconductor industry, pharmaceutical-grade pure water (such as water for injection/pure water)  
The deionized water used for analysis and experiment can reach the highest purity requirements. A variety of disinfection methods can be adopted, such as ozone disinfection method, hot water sterilization method or steam sterilization method

## IMPORTED MATERIALS OF POLYVINYLIDENE FLUORIDE (PVDF)

### 进口原料聚偏二氟乙烯 (PVDF) 高纯含氟聚合物

#### PVDF 管道和管件应用范围

(25年使用年限, 设计系数 C=2.0&1.6)

C=1.6 / PN16 SDR21 / S10      C=2.0 / PN16 SDR21 / S10      C=1.6 / PN10 SDR33 / S16      C=2.0 / PN10 SDR33 / S16

T(°F)

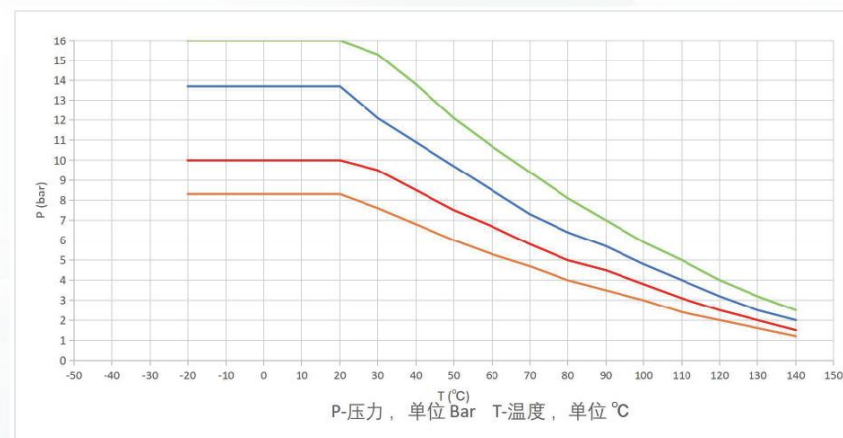

## SERIES AND SIZE OF PVDF PIPE

## PVDF-UHP 管材系列和规格尺寸

等级: PN16 Class: PN16 / 材质: PVDF 高纯型 Material: PVDF-UHP / 长度: 5米 Length: 5meters

d [mm]	di [mm]	e [mm]
20	16.2	1.9
25	21.2	1.9
32	27.2	2.4
40	35.2	2.4
50	44	3
63	57	3
75	67.8	3.6
90	81.4	4.3
110	99.4	5.3
125	113	6
140	126.6	6.7
160	144.6	7.7
200	180.8	9.6
225	203.4	10.8

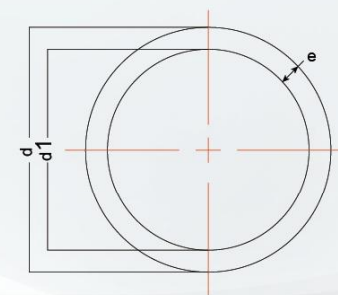

等级: PN10 Class: PN10 / 材质: PVDF 高纯型 Material: PVDF-UHP / 长度: 5米 Length: 5meters

d [mm]	di [mm]	e [mm]
90	84.4	2.8
110	103.2	3.4
125	117.2	3.9
140	131.4	4.3
160	150.2	4.9
200	187.6	6.2
225	211.2	6.9
280	262.8	8.6

管材 PIPE

## PVDF-UHP BUTT FUSION ELBOW 90°

PVDF 高纯型对焊 90° 弧形弯头

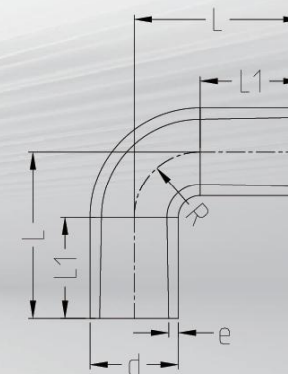

等级: PN16

Class: PN16

材质: PVDF 高纯型

Material: PVDF-UHP

等级: PN10

Class: PN10

材质: PVDF 高纯型

Material: PVDF-UHP

### 产品参数

d [mm]	L [mm]	L1 [mm]	R [mm]	e [mm]
20	38	23	15	1.9
25	42	23	19	1.9
32	46	21	24	2.4
40	51	21	30	2.4
50	58	21	37	3
63	66	21	45	3
75	100	25	75	3.6
90	115	25	90	4.3
110	135	25	110	5.3
125	125	28	116	6
140	140	33	125	6.7
160	160	33	145	7.7
200	200	33	185	9.6
225	220	33	205	10.8

d [mm]	L [mm]	L1 [mm]	R [mm]	e [mm]
90	115	25	90	2.8
110	135	25	110	3.4
125	125	28	116	3.9
140	140	33	125	4.3
160	160	33	145	4.9
200	200	33	185	6.2
225	220	33	205	6.9
280	298	40	265	8.6

# 管件 PIPE FITTING



## PVDF-UHP BUTT FUSION ELBOW 45°

PVDF 高纯型对焊 45° 弯头

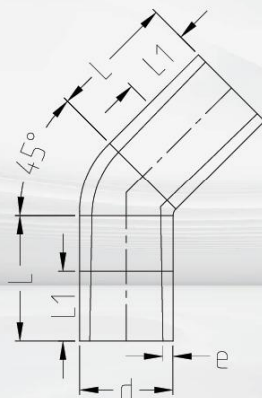

等级: PN16      Class: PN16  
 材质: PVDF 高纯型      Material: PVDF-UHP

### 产品参数

d [mm]	L [mm]	L1 [mm]	e [mm]
20	32	24	1.9
25	34	25	1.9
32	36	25	2.4
40	39	25	2.4
50	42	29	3
63	47	29	3
75	49	29	3.6
90	57	34	4.3
110	70	43	5.3
125	79	48	6
140	88	55	6.7
160	100	60	7.7
200	124	75	9.6
225	140	85	10.8

等级: PN10      Class: PN10  
 材质: PVDF 高纯型      Material: PVDF-UHP

d [mm]	L [mm]	L1 [mm]	e [mm]
90	57	34	2.8
110	70	43	3.4
125	79	48	3.9
140	88	55	4.3
160	100	60	4.9
200	124	75	6.2
225	140	85	6.9
280	183	112	8.6

## PVDF-UHP BUTT FUSION 90° TEE

PVDF 高纯型对焊 90° 正三通

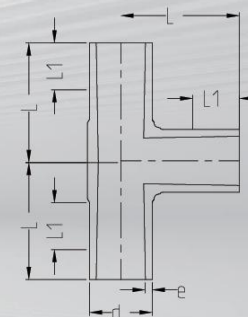

等级: PN16      Class: PN16  
 材质: PVDF 高纯型      Material: PVDF-UHP

### 产品参数

d [mm]	L [mm]	L1 [mm]	e [mm]
20	38	25	1.9
25	42	25	1.9
32	46	25	2.4
40	51	25	2.4
50	58	25	3
63	66	24	3
75	75	26	3.6
90	90	31	4.3
110	110	37	5.3
125	125	45	6
140	140	50	6.7
160	160	55	7.7
200	200	65	9.6
225	220	70	10.8

等级: PN10      Class: PN10  
 材质: PVDF 高纯型      Material: PVDF-UHP

d [mm]	L [mm]	L1 [mm]	e [mm]
90	90	31	2.8
110	110	37	3.4
125	125	45	3.9
140	140	50	4.3
160	160	55	4.9
200	200	65	6.2
225	220	70	6.9
280	256	74	8.6

## PVDF-UHP BUTT FUSION REDUCING TEE

PVDF 高纯型对焊 90° 异三通

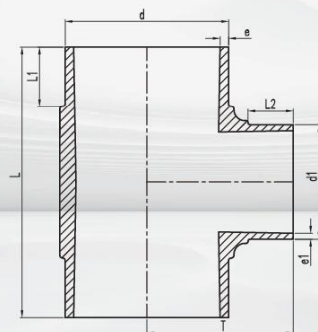

等级: PN16 CLASS: PN16  
材质: PVDF 高纯型 Material: PVDF-UHP

### 产品参数

d [mm]	d1 [mm]	L [mm]	L1 [mm]	e [mm]	L2 [mm]	e1 [mm]	T [mm]
63	32	96	24	3	25	2.4	64
90	63	150	31	4.3	24	3	81
110	63	176	37	5.3	24	3	93
110	90	204	37	5.3	31	4.3	101
140	110	256	50	6.7	37	5.3	129
160	63	226	55	7.7	24	3	123
160	90	254.5	55	7.7	31	4.3	130.5
160	110	276	55	7.7	37	5.3	141
225	90	295.5	70	10.8	31	4.3	165.5
225	110	317	70	10.8	37	5.3	186

等级: PN10 CLASS: PN10  
材质: PVDF 高纯型 Material: PVDF-UHP

### 产品参数

d [mm]	d1 [mm]	L [mm]	L1 [mm]	e [mm]	L2 [mm]	e1 [mm]	T [mm]
90	63	96	31	2.8	24	3	64
110	63	150	37	3.4	24	3	81
110	90	176	37	3.4	31	2.8	93
140	110	256	50	4.3	37	3.4	129
160	63	204	55	4.9	24	3	101
160	90	226	55	4.9	31	2.8	123
160	110	254.5	55	4.9	37	3.4	130.5
225	90	276	70	6.9	31	2.8	141
225	110	295.5	70	6.9	37	3.4	165.5
280	110	317	74	8.6	37	3.4	186
280	160	386	74	8.6	55	4.9	231

## PVDF-UHP BUTT FUSION CAP

PVDF 高纯型对焊 管帽

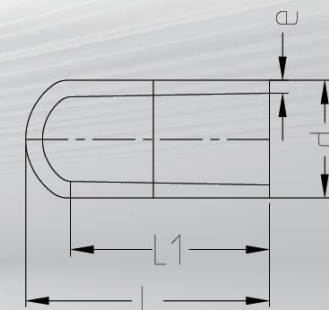

等级: PN16 Class: PN16  
材质: PVDF 高纯型 Material: PVDF-UHP

### 产品参数

d [mm]	L [mm]	L1 [mm]	e [mm]
20	42	34.2	1.9
25	50	39.3	1.9
32	55	41.7	2.4
40	65	48.2	2.4
50	70	49.1	3
63	80	56.7	3
75	90	59.3	3.6
90	105	65.8	4.3
110	125	79.4	5.3
125	50	22.0	6
140	60	27.4	6.7
160	76	38.0	7.7
225	105	58.0	10.8

等级: PN10 Class: PN10  
材质: PVDF 高纯型 Material: PVDF-UHP

d [mm]	L [mm]	L1 [mm]	e [mm]
90	105	65.8	2.8
110	125	79.4	3.4
125	50	22.0	3.9
140	60	27.4	4.3
160	76	38.0	4.9
225	105	58.0	6.9
280	124	64.0	8.6

## PVDF-UHP BUTT FUSION REDUCER

PVDF 高纯型对焊 异径

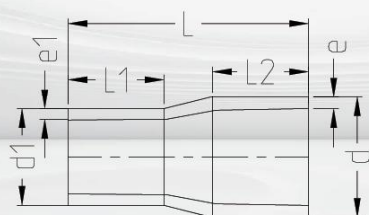

等级: PN16      Class: PN16  
 材质: PVDF 高纯型      Material: PVDF-UHP

### 产品参数

d [mm]	d1 [mm]	L [mm]	L1 [mm]	L2 [mm]	e [mm]	e1 [mm]
25	20	50	20	20	1.9	1.9
32	20	50	20	20	2.4	1.9
32	25	50	20	20	2.4	1.9
40	20	55	20	20	2.4	1.9
40	25	55	20	20	2.4	1.9
40	32	55	20	20	2.4	2.4
50	20	60	20	20	3	1.9
50	25	60	20	20	3	1.9
50	32	60	20	20	3	2.4
50	40	60	20	20	3	2.4
63	20	65	20	20	3	1.9
63	25	65	20	20	3	1.9
63	32	65	20	20	3	2.4
63	40	65	20	20	3	2.4
63	50	65	20	20	3	3
75	20	70	20	20	3.6	1.9
75	25	70	20	20	3.6	1.9
75	32	70	20	20	3.6	2.4
75	40	70	20	20	3.6	2.4
75	50	70	20	20	3.6	3
75	63	70	20	20	3.6	3
90	20	75	22	20	4.3	1.9
90	25	75	22	20	4.3	1.9
90	32	75	22	20	4.3	2.4
90	50	75	22	20	4.3	2.4
90	63	75	22	20	4.3	3
90	75	75	22	20	4.3	3.6
110	20	90	28	20	5.3	1.9
110	25	90	28	20	5.3	1.9
110	32	90	28	20	5.3	2.4
110	50	90	28	20	5.3	2.4
110	63	90	28	20	5.3	3
110	75	90	28	20	5.3	3.6
110	90	90	28	20	5.3	4.2
125	110	100	31	32	6	5.3
140	110	110	33	29	6.7	5.3
140	125	110	34	30	6.7	6
160	110	120	39	27	7.7	5.3
160	140	120	40	35	7.7	6.7
200	160	145	50	40	9.6	7.7
225	110	160	55	35	10.8	5.3
225	160	160	55	40	10.8	7.7
225	200	160	55	40	10.8	7.7
225	200	160	55	50	10.8	9.6

## PVDF-UHP BUTT FUSION FLANGE ADAPTER

PVDF 高纯型对焊 法兰适配器

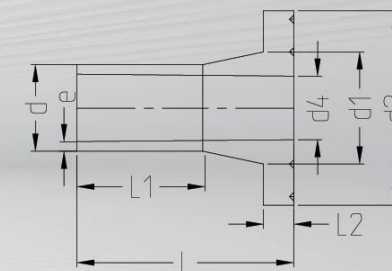

等级: PN16, 平面/细齿面组合      Class: PN16 平面/细齿面组合 Flat / fine tooth surface combination  
 材质: PVDF 高纯型      Material: PVDF-UHP

### 产品参数

d [mm]	DN [mm]	d1 [mm]	d2 [mm]	d4 [mm]	L [mm]	L [mm]	L2 [mm]	e [mm]
20	15	26	45	14.8	50	29	7	1.9
25	20	32	58	19.3	52	27	9	1.9
32	25	40	68	24.8	54	28	10	2.4
40	32	50	80	37.4	64	30	11	2.4
50	40	61	90	43.4	67	30	12	3
63	50	76	105	54.8	82	32	9	3
75	65	90	125	65.0	65.3	33.7	10	3.6
90	80	108	140	78.4	75.8	38.7	12	4.3
110	100	131	160	96.1	79.25	39	13	5.3
125	125	165	190	102	82	35	25	6
140	125	165	190	123.5	90	43	16	6.7
160	150	188	215	141.5	94	44	17	7.7
200	200	248	270	163	100	30	32	9.6
225	200	248	270	200.5	102	50	22	10.8

等级: PN10, 平面/细齿面组合      Class: PN10 Flat/Serrated surface combination      材质: PVDF 高纯型

d [mm]	DN [mm]	d1 [mm]	d2 [mm]	d4 [mm]	L [mm]	L [mm]	L2 [mm]	e [mm]
90	80	108	140	81.4	75.8	38.7	12	2.8
110	100	131	160	100.1	79.25	39	13	3.4
125	125	165	190	102	82	35	25	3.9
140	125	165	190	128.5	90	43	16	4.3
160	150	188	215	147.4	94	44	17	4.9
200	200	248	270	163	100	30	32	6.2
225	200	248	270	208.35	102	50	22	6.9
280	250	292	325	259.3	120	61.6	23	8.6

## PP-STEEL BACKING FLANGE

支撑法兰, 钢衬 PP

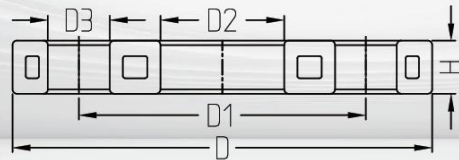

等级: PN16 CLASS: PN16

材质: 钢衬 PP(30%玻璃纤维增强) MATERIAL: Steel Lining PP (30% increase of glass fiber reinforced)

连接尺寸: IS7005, EN1092, BS4504, DIN2501 Connecting dimensions: IS7005, EN1092, BS4504, DIN2501

AL: 螺栓孔数 AL: number of holes / SC: 使用螺栓规格 SC: Bolt Specification

### 产品参数

d [mm]	DN [mm]	PN [bar]	D [mm]	D1 [mm]	D2 [mm]	D3 [mm]	H [mm]	AL [mm]
20	15	16	95	65	28	14	12	4
25	20	16	105	75	34	14	12	4
32	25	16	115	85	42	14	16	4
40	32	16	140	100	51	18	16	4
50	40	16	150	110	62	18	18	4
63	50	16	165	125	78	18	18	4
75	65	16	185	145	92	18	18	4
90	80	16	200	160	108	18	20	8
110	100	16	220	180	128	18	20	8
125	125	16	250	210	167	18	20	8
140	125	16	250	210	167	18	24	8
160	150	16	285	240	190	22	24	8
200	200	10	340	295	250	22	27	8
225	200	10	340	295	250	22	27	8
280	250	10	395	350	294	22	30	12

## PVDF-UHP BUTT FUSION MALE ADAPTOR

PVDF 高纯型对焊 适配接头

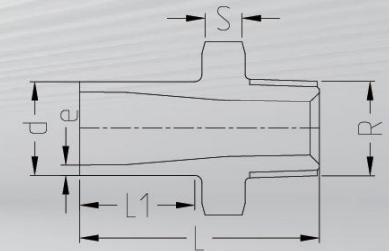

等级: PN16 CLASS: PN16 Material: PVDF-UHP

一端为对焊端, 一端为R外螺纹

One end is butt welding end, the other end is R type male thread

请勿使用对PVDF 高纯型有害的螺纹密封胶

Do not use thread sealants that are harmful to PVDF-UHP

安装时避免存留应力, 避免温度大范围循环变化

Avoid residual stress during installation and avoid large-scale cyclic changes in temperature

### 产品参数

d [mm]	weight [kg]	L [mm]	L1 [mm]	S [mm]	e [mm]	Rp[inch]
20		51	24.5	32	1.9	1/2
25		52	24	36	1.9	3/4
32		55	23	46	2.4	1
40		58	23	55	2.4	1 1/4
50		60	23.5	65	3	1 1/2
63		67	25	80	3	2

## PVDF-UHP BUTT FUSION FEMALE ADAPTOR

PVDF 高纯型对焊 适配缩节

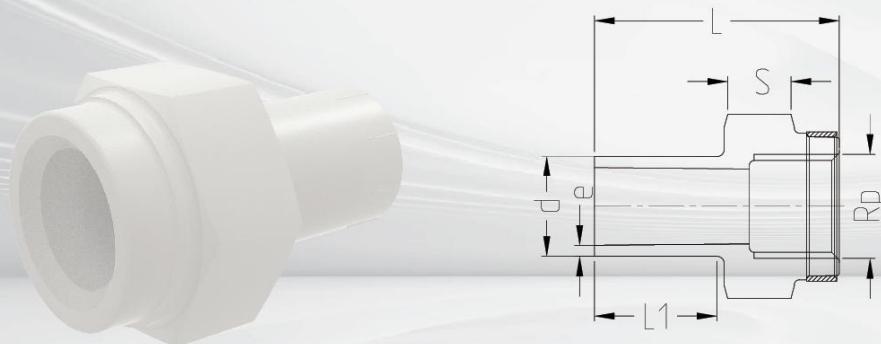

等级: PN16 CLASS: PN16 Material: PVDF-UHP

一端为对焊端, 一端为Rp内螺纹

With butt fusion spigot and the other end is female thread Rp

只可连接塑料螺纹

Plastic Threads Connection only

请勿使用对PVDF 高纯型有害的螺纹密封胶

Do not use thread sealing pastes that are harmful to PVDF

安装时避免残留应力, 避免温度大范围循环变化

Avoid residual stress during installation and avoid large-scale cyclic changes in temperature

### 产品参数

d [mm]	L [mm]	L1 [mm]	S [mm]	e [mm]	Rp[inch]
20	49	24.5	32	1.9	1/2
25	51	24	36	1.9	3/4
32	55	23	46	2.4	1
40	57	23	55	2.4	1 1/4
50	60	23.5	65	3	1 1/2
63	62	25	80	3	2

## PVDF-UHP BUTT FUSION UNION

PVDF 高纯型对焊 活接

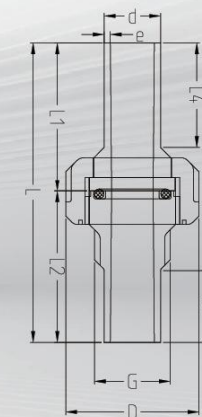

等级: PN16 CLASS: PN16 Material: PVDF-UHP

垫片: FPM O型圈 Gasket: FPM O-ring

### 产品参数

d [mm]	D [mm]	L [mm]	L1 [mm]	L2 [mm]	L3 [mm]	L4 [mm]	G [inch]	E [mm]
20	47.5	107	53	54	25	37	1	1.9
25	58	112	56	56	25	26	1 1/4	1.9
32	65	120	60	60	25	42	1 1/2	2.4
40	77	126	63	63	26	42	2	2.4
50	84	131	65.5	65.5	26	45	2 1/4	3
63	105	137	68	69	27	45	2 1/2	3

## PVDF TO PFA ADAPTOR

### PVDF 转 PFA 接头

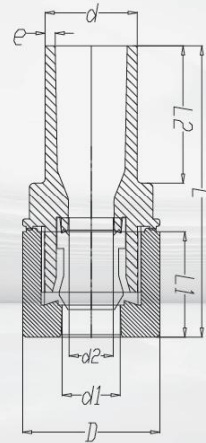

等级: PN16 CLASS: PN16 材质: PVDF 高纯型 Material: PVDF-UHP

### 产品参数

d [mm]	PFA 接头	D [mm]	e [mm]	d1 [mm]	d2 [mm]	L [mm]	L1 [inch]	L2 [mm]
20	1/4"	17	1.9	6.4	3.2	55.4	17	30
20	3/8"	23	1.9	9.7	8	60.7	20	30
20	1/2"	30	1.9	12.7	9.6	63.8	23	30
20	3/4"	40.6	1.9	19	15.8	76.3	33	30
25	1/4"	17	1.9	6.4	3.2	55.4	17	30
25	3/8"	23	1.9	9.7	8	60.7	20	30
25	1/2"	30	1.9	12.7	9.6	63.8	23	30
25	3/4"	40.6	1.9	19	15.8	76.3	33	30
25	1"	49	1.9	25.4	22.2	79.4	37	30
32	1/2"	30	2.4	12.7	9.6	63.8	23	30
32	3/4"	40.6	2.4	19	15.8	76.3	33	30
32	1"	49	2.4	25.4	22.2	79.4	37	30

## INSTRUMENT CONNECTOR

### 仪表接头

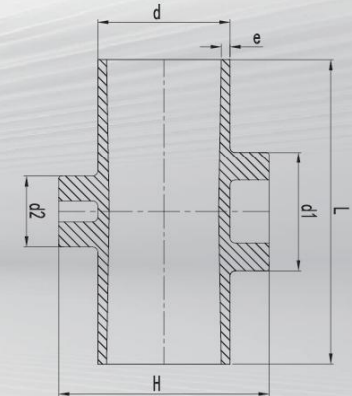
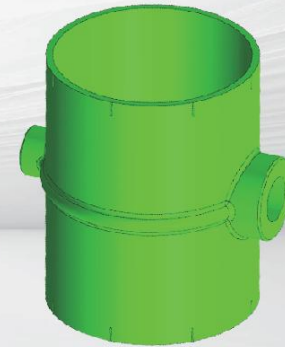

等级: PN16 CLASS: PN16  
材质: PVDF 高纯型 Material: PVDF-UHP

### 产品参数

d [mm]	d1 [mm]	d2 [mm]	L [mm]	H [mm]	e [mm]
d32	45.2	27	92	60	2.4
d50	45.2	27	116	80	3
d63	45.2	27	120	93	3
d75	45.2	27	120	105	3.6
d90	45.2	27	140	118.2	4.3
d110	45.2	27	140	138.2	5.3
d140	45.2	27	160	164.6	6.7
d160	45.2	27	160	184.7	7.7
d225	45.2	27	160	246.1	10.8

等级: PN10 CLASS: PN10  
材质: PVDF 高纯型 Material: PVDF-UHP

d [mm]	d1 [mm]	d2 [mm]	L [mm]	H [mm]	e [mm]
d90	45.2	27	140	118.2	2.8
d110	45.2	27	140	138.2	3.4
d140	45.2	27	160	164.6	4.3
d160	45.2	27	160	184.7	4.9
d225	45.2	27	160	246.1	6.9
d280	45.2	27	160	301.4	8.6

## PVDF-UHP BUTT FUSION TRUE UNION BALL VALVE

PVDF 对焊 双由任球阀

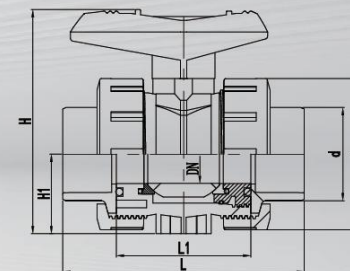
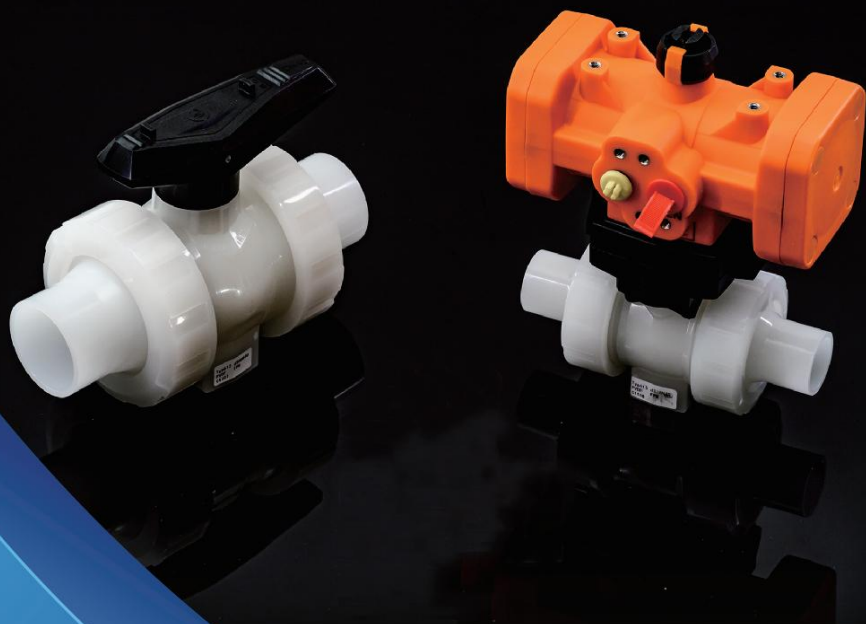

等级: PN16 CLASS: PN16 材质: PVDF Material: PVDF-UHP

垫片: FPM O型圈 PTFE球密封 内置不锈钢固定螺帽 Built-in Stainless fixed nut

### 产品参数

d [mm]	DN [mm]	D [mm]	L [mm]	L1 [mm]	H [mm]	H1 [mm]
20	15	50.00	130.00	55.00	82.80	26.30
25	20	59.00	143.00	65.00	92.80	30.60
32	25	70.00	150.00	70.00	109.20	39.10
40	32	85.00	170.00	84.00	131.80	44.20
50	40	99.00	190.00	88.00	143.20	52.20
63	50	125.00	220.00	100.00	175.70	71.30
75	65	158.60	265.60	135.00	231.50	82.80
90	80	192.10	291.60	140.00	260.60	99.30
110	100	223.60	320.50	162.00	292.10	115.20

# 阀门 VALVE

## PVDF-UHP BUTT FUSION PLASTIC PNEUMATIC TRUE UNION BALL VALVE

PVDF 高纯型对焊 全塑气动双由任球阀

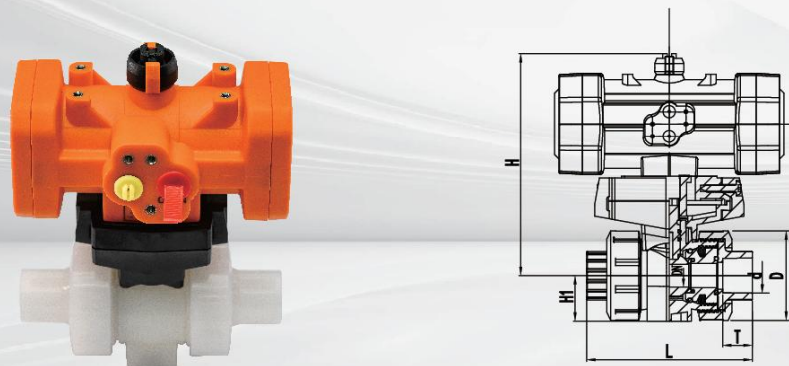

等级: PN16 CLASS: PN16 材质: PVDF 高纯型 Material: PVDF-UHP

垫片: FPM O型圈 Gasket: FPM O-ring

PTFE球密封 Ball seals PTFE 内置不锈钢固定螺帽 Built-in Stainless fixed nut

执行器: 单作用, 弹簧自动复位, 常闭

Actuator: Single-acting, spring automatic return, normally closed

打开和关闭时间: 1-2S Opening and closing time: 1-2s

全塑料外壳, 可以在高腐蚀环境中使用 All plastic shell, which can be used in highly corrosive environment

可以配套电磁阀及位置开关使用 Matching with solenoid valves and position switch

## 产品参数

d [mm]	DN [mm]	D [mm]	L [mm]	H [mm]	D1 [mm]
20	15	50.00	130.00	159.00	26.30
25	20	59.00	143.00	168.00	30.60
32	25	70.00	150.00	168.00	39.10
40	32	85.00	170.00	202.00	44.20
50	40	99.00	190.00	202.00	52.20
63	50	125.00	220.00	225.00	71.30
75	65	158.60	265.60	321.40	82.80
90	80	192.10	291.60	334.00	99.30
110	100	223.60	320.50	346.00	115.20

## PVDF-UHP TRUE UNION DIAPHRAGM VALVE BUTT FUSION TYPE

PVDF 高纯型对焊 由令式隔膜阀



等级: PN16 CLASS: PN16 材质: PVDF 高纯型 Material: PVDF-UHP

垫片: FPM O型圈 Gasket: FPM O-ring

PTFE球密封 Ball seals PTFE 内置不锈钢固定螺帽 Built-in Stainless fixed nut

## 产品参数

d [mm]	DN [mm]	D [mm]	L [mm]	L1 [mm]	H [mm]	H1 [mm]	D1 [mm]
20	15	46.50	201.00	95.00	90.00	14.00	80.00
25	20	53.50	230.00	118.00	102.00	18.00	80.00
32	25	64.00	243.00	123.00	119.00	21.00	94.00
40	32	74.50	267.00	141.00	126.00	26.00	117.00
50	40	85.00	291.00	161.00	139.00	33.00	117.00
63	50	100.00	327.00	191.00	172.00	39.00	152.00



## PVDF-UHP BUTT FUSION DIAPHRAGM VALVE

PVDF 高纯型对焊 隔膜阀

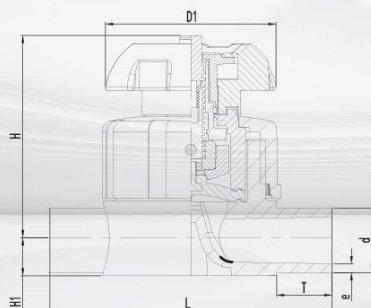

等级: PN16 CLASS: PN16 材质: PVDF 高纯型 Material: PVDF-UHP

垫片: FPM O型圈 Gasket: FPM O-ring

PTFE球密封 Ball seals PTFE 内置不锈钢固定螺帽 Built-in Stainless fixed nut

## 产品参数

d [mm]	DN [mm]	T [mm]	L [mm]	e[mm]	H [mm]	H1 [mm]	D1 [mm]
20	15	30.00	134.00	1.9	90.00	14.00	80.00
25	20	30.00	144.00	1.9	102.00	18.00	80.00
32	25	30.00	154.00	2.4	119.00	21.00	94.00
40	32	30.00	174.00	2.4	126.00	26.00	117.00
50	40	33.00	194.00	3	139.00	33.00	117.00
63	50	39.00	234.00	3	172.00	39.00	152.00
75	65	39	275	3.6	173	91	151.6
90	80	40	290	4.3	226	109	263
110	100	42	350	5.3	234	134	263

## PVDF-UHP FLANGED DIAPHRAGM VALVE

PVDF 高纯型法兰式 隔膜阀

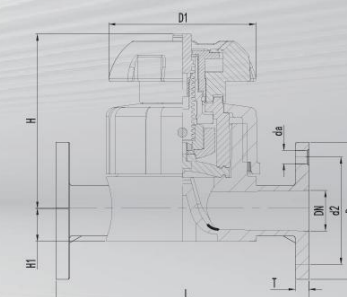
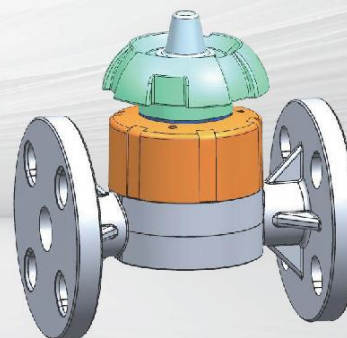

等级: PN16 CLASS: PN16 材质: PVDF Material: PVDF-UHP

垫片: FPM O型圈 PTFE球密封 内置不锈钢固定螺帽 Built-in Stainless fixed nut

## 产品参数

d [mm]	DN[mm]	D [mm]	L [mm]	T [mm]	H [mm]	H1[mm]	D1 [mm]	d2 [mm]	da [mm]	螺孔数 n
20	15	95.00	136.00	15.00	90.00	14.00	80.00	65	14	4
25	20	105.00	152.00	15.00	102.00	18.00	80.00	75	14	4
32	25	125.00	164.00	15.00	119.00	21.00	94.00	85	14	4
40	32	140.00	188.00	17.00	126.00	26.00	117.00	100	16	4
50	40	150.00	208.00	19.00	139.00	33.00	117.00	110	16	4
63	50	165.00	252.00	20.00	172.00	39.00	152.00	125	19	4
75	65	185	290	17	173	91	151.6	145	19	4
90	80	200	310	18	226	109	263	160	19	8
110	100	220	350	20	234	134	263	180	19	8
140	125	250	350	22	234	134	263	210	22	8
160	150	286	480	24	333	212	292.6	240	22	8

## PVDF-UHP TRUE UNION PNEUMATIC DIAPHRAGM VALVE BUTT FUSION TYPE

## PVDF 高纯型对焊 全塑气动由令隔膜阀

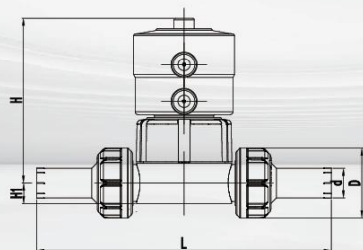

等级: PN6 CLASS: PN6 材质: PVDF 高纯型 Material: PVDF-UHP

垫片: FPM O型圈 Gasket: FPM O-ring EPDM/PTFE复合膜片 EPDM/PTFE Seal

执行器: 单作用, 弹簧自动复位, 常闭:

Actuator: Single-acting, spring automatic return, normally closed

打开和关闭时间: 1-2S

Opening and closing time: 1-2s

全塑料外壳, 可以在高腐蚀环境中使用:

All plastic shell, which can be used in highly corrosive environment

## 产品参数

d [mm]	L [mm]	D [mm]	H [mm]	H1 [mm]
20	152.50	46.50	112.00	14.00
25	165.50	53.50	120.00	18.00
32	243.00	64.00	119.00	21.00
40	267.00	74.50	126.00	26.00
50	291.00	85.00	139.00	33.00
63	327.00	100.00	172.00	39.00

## PVDF-UHP BUTT FUSION PLASTIC PNEUMATIC DIAPHRAGM VALVE

## PVDF 高纯型对焊 全塑气动隔膜阀

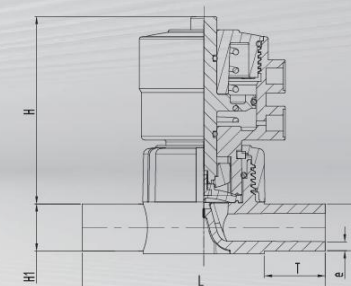

等级: PN6 CLASS: PN6 材质: PVDF 高纯型 Material: PVDF-UHP

垫片: FPM O型圈 Gasket: FPM O-ring EPDM/PTFE复合膜片 EPDM/PTFE Seal

执行器: 单作用, 弹簧自动复位, 常闭:

Actuator: Single-acting, spring automatic return, normally closed

打开和关闭时间: 1-2S

Opening and closing time: 1-2s

全塑料外壳, 可以在高腐蚀环境中使用:

All plastic shell, which can be used in highly corrosive environment

## 产品参数

d [mm]	L [mm]	T [mm]	H [mm]	H1 [mm]	e [mm]
20	134.00	30.00	112.00	14.00	1.9
25	144.00	30.00	120.00	18.00	1.9
32	154.00	30.00	119.00	21.00	2.4
40	174.00	30.00	126.00	26.00	2.4
50	194.00	33.00	139.00	33.00	3
63	234.00	39.00	172.00	39.00	3

## PVDF-UHP BUTT FUSION T-DIAPHRAGM VALVE(MANUAL)

PVDF 高纯型对焊 T 型手动隔膜阀

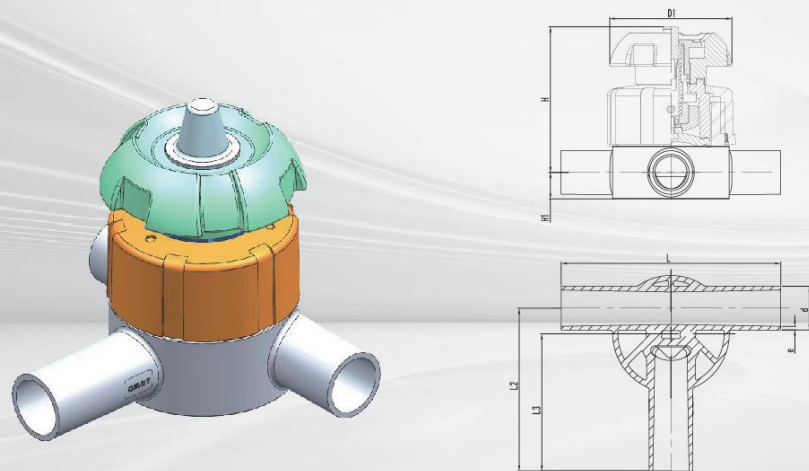

等级: PN16 CLASS: PN16 材质: PVDF 高纯型 Material: PVDF-UHP

垫片: FPM O型圈 EPDM/PTFE复合膜片 内置不锈钢固定螺帽 Built-in Stainless fixed nut

## 产品参数

d [mm]	DN[mm]	L [mm]	e [mm]	H [mm]	H1[mm]	D1 [mm]	L2 [mm]	L3 [mm]
20	15	162.00	1.90	90	14.00	80.00	96.00	84
25	20	162.00	1.90	102	18.00	80.00	108.00	92
32	25	162.00	2.40	119	21.00	94.00	120.00	101
50	40	209.00	3.00	139	33.00	117.00	169.00	136
63	50	220.00	3.00	172	39.00	152.00	192.00	153

## PVDF-UHP BUTT FUSION REDUCING T-DIAPHRAGM VALVE(MANUAL)

PVDF 高纯型对焊 T 型异径手动隔膜阀

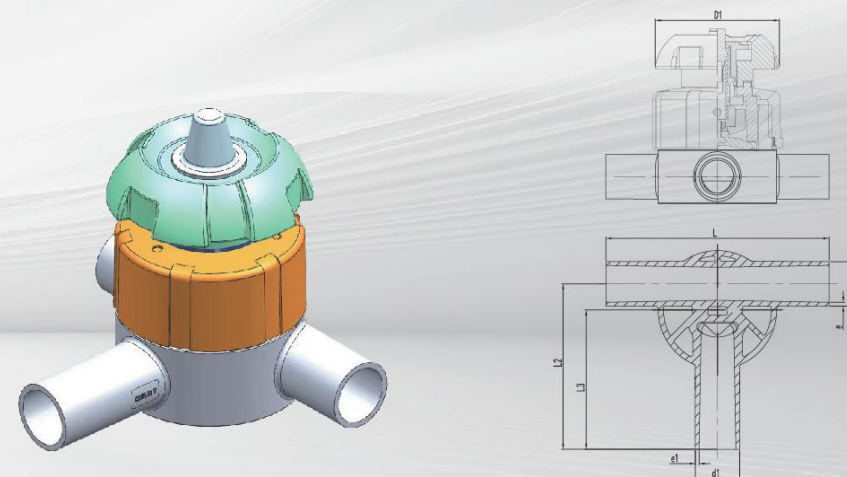

等级: PN16 CLASS: PN16 材质: PVDF 高纯型 Material: PVDF-UHP

垫片: FPM O型圈 EPDM/PTFE复合膜片 内置不锈钢固定螺帽 Built-in Stainless fixed nut

## 产品参数

d [mm]	d1 [mm]	L [mm]	e [mm]	H [mm]	H1 [mm]	D1 [mm]	L2 [mm]	L3 [mm]	e1 [mm]
50	20	209.00	3.00	139	33	119.00	159.00	126	1.9

## PVDF-UHP BUTT FUSION T-DIAPHRAGM VALVE (PNEUMATIC)

## PVDF 高纯型对焊 T 型气动隔膜阀

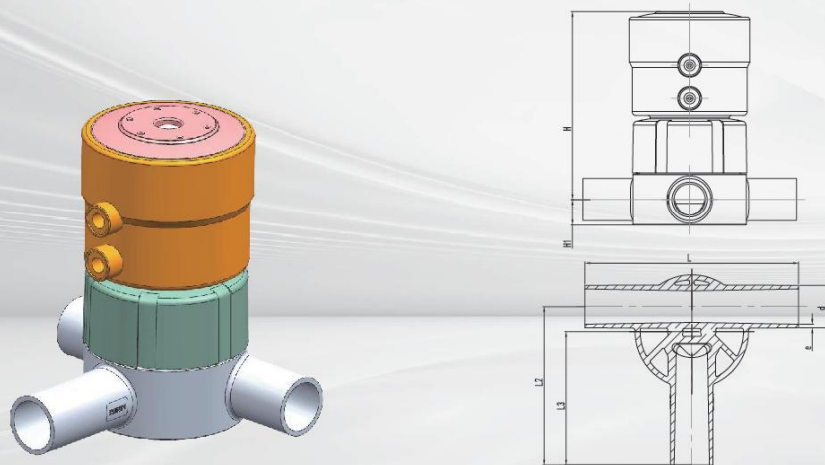

等级: PN16 CLASS: PN16 材质: PVDF 高纯型 Material: PVDF-UHP  
 垫片: FPM O型圈 EPDM/PTFE复合膜片 内置不锈钢固定螺帽 Built-in Stainless fixed nut

## 产品参数

d [mm]	DN [mm]	L [mm]	e [mm]	H [mm]	H1 [mm]	L2[mm]	L3 [mm]
20	15	162.00	1.90	112	14.00	96.00	84
25	20	162.00	1.90	120	18.00	108.00	92
32	25	162.00	2.40	119	21.00	120.00	101
50	40	209.00	3.00	139	33.00	169.00	136
63	50	220.00	3.00	172	39.00	192.00	153

## PVDF-UHP BUTT FUSION REDUCING T-DIAPHRAGM VALVE (PNEUMATIC)

## PVDF 高纯型对焊 T 型异径气动隔膜阀

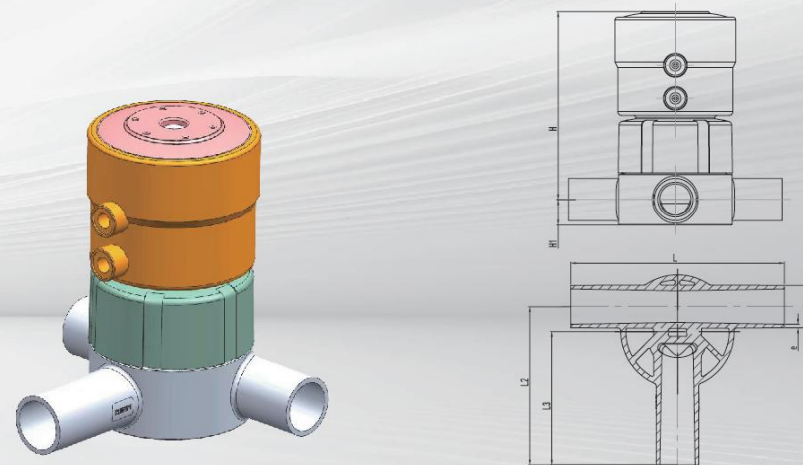

等级: PN16 CLASS: PN16 材质: PVDF 高纯型 Material: PVDF-UHP  
 垫片: FPM O型圈 EPDM/PTFE复合膜片 内置不锈钢固定螺帽 Built-in Stainless fixed nut

## 产品参数

d [mm]	DN [mm]	L [mm]	e [mm]	H [mm]	H1 [mm]	L2[mm]	L3 [mm]
20	15	162.00	1.90	112	14.00	96.00	84
25	20	162.00	1.90	120	18.00	108.00	92
32	25	162.00	2.40	119	21.00	120.00	101
50	40	209.00	3.00	139	33.00	169.00	136
63	50	220.00	3.00	172	39.00	192.00	153

## PVDF-UHP TRUE UNION ELECTRIC DIAPHRAGM VALVE BUTT FUSION TYPE

### PVDF 高纯型对焊 电动由令式隔膜阀



等级: PN16 CLASS: PN16 材质: PVDF 高纯型 Material: PVDF-UHP  
 垫片: FPM O型圈 Gasket: FPM O-ring EPDM/PTFE复合膜片 EPDM/PTFE Seal

### 产品参数

d [mm]	DN [mm]	D [mm]	L [mm]	D1 [mm]	H [mm]	H1 [mm]
20	15	64.00	203.00	116.00	194.00	38.00
25	20	64.00	203.00	116.00	194.00	38.00
32	25	64.00	243.00	116.00	194.00	38.00
40	32	100.00	311.00	178.00	275.00	65.00
50	40	100.00	311.00	178.00	275.00	65.00
63	50	100.00	327.00	178.00	275.00	65.00